

D Turn

D Mill

D Drill

D Cut

Duracarb

Products Catalog



Quality Standard

DURACARB has been certified by the prestigious Standards Institution, as being in full compliance with Quality and Environmental & Occupational Health and Safety Management Standards.

In addition, completed products are inspected before shipping, to ensure delivery of the finest quality goods. Quality control facilities include the metallurgical laboratory, raw metal testing, an online testing procedure and a machining center for tool performance testing and final product inspection.

Only the finest products are packaged for entry into DURACARB's inventory.



Grades	4
D Turn	8
ISO TURN INSERT	9
ISO EXTERNAL HOLDER	24
ISO BORING BAR	40
ISO TURN CERAMIC INSERTS	47
ISO CERAMIC HOLDERS	51
D Cut	54
D Thread	74
THREAD INSERTS	76
THREAD HOLDERS	85
D Drill	92
DEC-DRILL INSERTS	94
DEC-DRILL	95
FLEX HEAD DRILL	99
FLEX HEAD INSERTS	101
D Mill	102
D-MILL INSERTS	103
D-MILL CUTTERS	107
Technical Information	141
Index	

Grade



GRADE	ISO RANGE	FEATURES & APPLICATION
DC210 UNCOATED	N10	<ul style="list-style-type: none"> • For Aluminum machining • Uncoated grade
DC610 CERMET	P05 – P15 M05 – M15 K05 – K15	<ul style="list-style-type: none"> • Finishing & Semi finishing of Steel, Cast Iron and Stainless Steel • General turning in Steel machining • Covering wide application range
DC820 CVD COATED	K05 – K15	<ul style="list-style-type: none"> • High speed machining in Cast Iron machining • Combination thick Al₂O₃ coating layer and high wear resistant substrate for extreme wear resistance. • TiCN-Al₂O₃-TiN
DC9015 CVD COATED	P10 – P25	<ul style="list-style-type: none"> • First recommendation for high speed machining in Steel • Good combinaton wear resistance and toughness • TiN-TiCN-Al₂O₃-TiN • Improved chipping resistance
DC9025 CVD COATED	P15 – P35	<ul style="list-style-type: none"> • For general machining in Steel • Wide application range thanks to good wear resistance and toughness. • TiN-TiCN-Al₂O₃-TiN • Improved chipping resistance
DC8035 CVD COATED	P20 – P40 M30 – M40	<ul style="list-style-type: none"> • For Low Carbon Steel, Low Carbon Alloy Steel and Stainless Steel • Interrupted cutting in general Steel • Excellent toughness • TiN-TiCN-Al₂O₃-TiN



Ceramic

GRADE	ISO RANGE	FEATURES & APPLICATION
DC11	<div style="display: flex; justify-content: space-between;"> <div style="background-color: red; color: white; padding: 2px;">K01</div> <div style="border-left: 1px solid black; padding: 0 5px;">—</div> <div style="background-color: red; color: white; padding: 2px;">K10</div> </div> <div style="display: flex; justify-content: space-between; margin-top: 2px;"> <div style="background-color: orange; color: white; padding: 2px;">S01</div> <div style="border-left: 1px solid black; padding: 0 5px;">—</div> <div style="background-color: orange; color: white; padding: 2px;">S10</div> </div>	<ul style="list-style-type: none"> • White ceramic, features high toughness and wear resistance. • Used for high speed turning of cast iron.
DC22	<div style="display: flex; justify-content: space-between;"> <div style="background-color: grey; color: white; padding: 2px;">H05</div> <div style="border-left: 1px solid black; padding: 0 5px;">—</div> <div style="background-color: grey; color: white; padding: 2px;">H25</div> </div> <div style="display: flex; justify-content: space-between; margin-top: 2px;"> <div style="background-color: red; color: white; padding: 2px;">K05</div> <div style="border-left: 1px solid black; padding: 0 5px;">—</div> <div style="background-color: red; color: white; padding: 2px;">K10</div> </div>	<ul style="list-style-type: none"> • Black ceramic ($Al_2O_3/TiCN$), used for high speed, light roughing and finishing of hardened steel and chilled cast iron.
DC23	<div style="display: flex; justify-content: space-between;"> <div style="background-color: grey; color: white; padding: 2px;">H10</div> <div style="border-left: 1px solid black; padding: 0 5px;">—</div> <div style="background-color: grey; color: white; padding: 2px;">H30</div> </div> <div style="display: flex; justify-content: space-between; margin-top: 2px;"> <div style="background-color: red; color: white; padding: 2px;">K05</div> <div style="border-left: 1px solid black; padding: 0 5px;">—</div> <div style="background-color: red; color: white; padding: 2px;">K15</div> </div>	<ul style="list-style-type: none"> • Black ceramic ($Al_2O_3/TiCN$), used for machining grey and nodular cast iron at medium to finishing conditions.
DC6	<div style="display: flex; justify-content: space-between;"> <div style="background-color: red; color: white; padding: 2px;">K01</div> <div style="border-left: 1px solid black; padding: 0 5px;">—</div> <div style="background-color: red; color: white; padding: 2px;">K10</div> </div>	<ul style="list-style-type: none"> • SiAlON based ceramic grade for high speed machining of cast iron. • Used for roughing and finishing at both wet and dry conditions of automotive parts such as brake drum, brake disk, etc. • Provides high productivity also in roughing of mill rolls made of High-Cr steel and HSS.
DC8	<div style="display: flex; justify-content: space-between;"> <div style="background-color: red; color: white; padding: 2px;">K01</div> <div style="border-left: 1px solid black; padding: 0 5px;">—</div> <div style="background-color: red; color: white; padding: 2px;">K20</div> </div>	<ul style="list-style-type: none"> • A silicon nitride grade, used for medium turning and milling applications. Can be used for interrupted cuts. Cutting speed range: 100-1500 m/min, feed range: 0.1-1.0 mm/rev.
DC9	<div style="display: flex; justify-content: space-between;"> <div style="background-color: orange; color: white; padding: 2px;">S20</div> <div style="border-left: 1px solid black; padding: 0 5px;">—</div> <div style="background-color: orange; color: white; padding: 2px;">S30</div> </div>	<ul style="list-style-type: none"> • A silicon nitride ceramic grade, recommended for high speed machining and interrupted cut for nickel based, heat resistant alloys such as Inconel, Waspaloy and Rene.
DC80	<div style="display: flex; justify-content: space-between;"> <div style="background-color: red; color: white; padding: 2px;">K01</div> <div style="border-left: 1px solid black; padding: 0 5px;">—</div> <div style="background-color: red; color: white; padding: 2px;">K20</div> </div>	<ul style="list-style-type: none"> • A CVD coated Si_3N_4 ceramic grade. Used for rough turning and milling of grey and nodular cast iron.
DC420	<div style="display: flex; justify-content: space-between;"> <div style="background-color: grey; color: white; padding: 2px;">H05</div> <div style="border-left: 1px solid black; padding: 0 5px;">—</div> <div style="background-color: grey; color: white; padding: 2px;">H25</div> </div> <div style="display: flex; justify-content: space-between; margin-top: 2px;"> <div style="background-color: red; color: white; padding: 2px;">K05</div> <div style="border-left: 1px solid black; padding: 0 5px;">—</div> <div style="background-color: red; color: white; padding: 2px;">K10</div> </div>	<ul style="list-style-type: none"> • Black ceramic ($Al_2O_3/TiCN$) TiN PVD coated, used for light roughing and finishing for high speed machining of hardened steel, chilled cast iron, high chromium steel, etc.
DW7	<div style="display: flex; justify-content: space-between;"> <div style="background-color: grey; color: white; padding: 2px;">H05</div> <div style="border-left: 1px solid black; padding: 0 5px;">—</div> <div style="background-color: grey; color: white; padding: 2px;">H25</div> </div> <div style="display: flex; justify-content: space-between; margin-top: 2px;"> <div style="background-color: orange; color: white; padding: 2px;">S20</div> <div style="border-left: 1px solid black; padding: 0 5px;">—</div> <div style="background-color: orange; color: white; padding: 2px;">S30</div> </div>	<ul style="list-style-type: none"> • Whisker reinforced ceramic grade for machining high nickel alloys and hardened steel.

Grade



GRADE	ISO RANGE	FEATURES & APPLICATION															
DC9800 PVD COATED	<table border="0"> <tr><td>P15</td><td>—</td><td>P35</td></tr> <tr><td>M10</td><td>—</td><td>M30</td></tr> <tr><td>K10</td><td>—</td><td>K30</td></tr> <tr><td>S10</td><td>—</td><td>S25</td></tr> </table>	P15	—	P35	M10	—	M30	K10	—	K30	S10	—	S25	<ul style="list-style-type: none"> • For steel and stainless steel machining • Improved tool life • TiAlN 			
P15	—	P35															
M10	—	M30															
K10	—	K30															
S10	—	S25															
DC9235 PVD COATED	<table border="0"> <tr><td>P30</td><td>—</td><td>P45</td></tr> <tr><td>M30</td><td>—</td><td>M45</td></tr> <tr><td>K20</td><td>—</td><td>K40</td></tr> <tr><td>N15</td><td>—</td><td>N30</td></tr> <tr><td>S20</td><td>—</td><td>S30</td></tr> </table>	P30	—	P45	M30	—	M45	K20	—	K40	N15	—	N30	S20	—	S30	<ul style="list-style-type: none"> • For roughing and low speed applications, high feed machining of steel, stainless steel and cast iron • Coated grade with improved edge strength • TiCN
P30	—	P45															
M30	—	M45															
K20	—	K40															
N15	—	N30															
S20	—	S30															
DC120 PVD COATED	<table border="0"> <tr><td>P15</td><td>—</td><td>P30</td></tr> <tr><td>K10</td><td>—</td><td>K20</td></tr> </table>	P15	—	P30	K10	—	K20	<ul style="list-style-type: none"> • Very successful on stainless steel, cast iron and nonferrous materials, good also for interrupted cuts • Has low wear resistance 									
P15	—	P30															
K10	—	K20															
DC610 UNCOATED	<table border="0"> <tr><td>P05</td><td>—</td><td>P25</td></tr> <tr><td>M05</td><td>—</td><td>M15</td></tr> <tr><td>K05</td><td>—</td><td>K15</td></tr> </table>	P05	—	P25	M05	—	M15	K05	—	K15	<ul style="list-style-type: none"> • A cermet grade, used for grooving and turning applications. Recommended for semi-finishing and finishing operations when excellent surface finish is required. Wear resistant, prevents built-up edge. 						
P05	—	P25															
M05	—	M15															
K05	—	K15															



GRADE	ISO RANGE	FEATURES & APPLICATION															
DC610 CERMET	<table border="0"> <tr><td>P05</td><td>—</td><td>P15</td></tr> <tr><td>M05</td><td>—</td><td>M15</td></tr> <tr><td>K05</td><td>—</td><td>K15</td></tr> </table>	P05	—	P15	M05	—	M15	K05	—	K15	<ul style="list-style-type: none"> • Finishing & Semi finishing of Steel, Cast Iron and Stainless Steel • General turning in Steel machining • Covering wide application range 						
P05	—	P15															
M05	—	M15															
K05	—	K15															
DC9800 PVD COATED	<table border="0"> <tr><td>M10</td><td>—</td><td>M30</td></tr> <tr><td>P15</td><td>—</td><td>P35</td></tr> <tr><td>K10</td><td>—</td><td>K30</td></tr> <tr><td>S10</td><td>—</td><td>S25</td></tr> <tr><td>H15</td><td>—</td><td>H30</td></tr> </table>	M10	—	M30	P15	—	P35	K10	—	K30	S10	—	S25	H15	—	H30	<ul style="list-style-type: none"> • For Steel and Stainless Steel machining • Improved tool life • TiAlN
M10	—	M30															
P15	—	P35															
K10	—	K30															
S10	—	S25															
H15	—	H30															

Grade



GRADE	ISO RANGE	FEATURES & APPLICATION
DC210 UNCOATED	K10	<ul style="list-style-type: none"> • For Cast Iron milling • Uncoated grade
DC325M UNCOATED	P30 — P40	<ul style="list-style-type: none"> • For Steel milling • Uncoated grade
DC7800 CVD COATED	P10 — P20 M10 — M20	<ul style="list-style-type: none"> • For heavy duty applications in milling of steel • Improved edge strenght and better toughness
DC9235 PVD COATED	M30 — M40 P30 — P45 K20 — K40 N15 — N30 S20 — S30	<ul style="list-style-type: none"> • Interrupted and rough machining of steel and stainless steel • Low speed and interrupted machining of heat-resistant alloy
DP7320 PVD COATED	K05 — K20	<ul style="list-style-type: none"> • General machining for gray and ductile cast iron • Finish and medium machining of hardened steel
DP9320 PVD COATED	P05 — P25 K05 — K25	<ul style="list-style-type: none"> • General milling of steel • Heavy interrupted cutting of cast iron
DP5320 PVD COATED	P15 — P35 M10 — M30 S15 — S25	<ul style="list-style-type: none"> • General machining of steel, stainless steel and heat-resistant alloy
DC154 PVD COATED	P20 — P35	<ul style="list-style-type: none"> • For heavy duty applications in milling of steel • Improved edge strenght and better toughness
DC9800 PVD COATED	M10 — M30 P15 — P35 K10 — K30 S10 — S25 H15 — H30	<ul style="list-style-type: none"> • For semi -roughing and medium machining applications • Optimum mechanical shock resistance • TiAIN
DP8330 PVD COATED	P30 — P45 M25 — M40 S15 — S30	<ul style="list-style-type: none"> • High mechanical shock resistance • PVD TiAIN coating • For semi -roughing and medium machining applications • TiAIN + TiN



Insert Designation System

1. Shape

2. Clearance Angle

3. Tolerance

Tolerance mm		
IC	m±	d±
6.35	±0.08	±0.05
9.52	±0.08	±0.05
12.70	±0.13	±0.08

Sign	m	t	d
H	±0.013	±0.025	±0.013
E	±0.025	±0.025	±0.025
G	±0.025	±0.13	±0.025

4. Type

- N** No chipbreaker
No hole
- A** No chipbreaker
Straight hole
- F** Double-sided CB
No hole
- G** Single-sided CB
Straight hole
- M** Single-sided CB
Straight hole
- R** Single-sided CB
No hole
- W, B** No chipbreaker
Screw hole
- T, H** Single-sided CB
Screw hole
- Z, X** Special

6. Thickness

- 02 = 2.38mm
- 03 = 3.18mm
- T3 = 3.97mm
- 04 = 4.76mm
- 06 = 6.35mm
- 07 = 7.94mm
- 09 = 9.52mm

C N M G 12 04 08 (R) 52

1 2 3 4 5 6 7 8 9

5. Cutting Edge Length

IC(mm)	C	D	R	S	T	V	W	K
3.97	03	04		03	06		02	
4.76	04	05		04	08	08		
5.56	05	06		05	09	09	03	
6.35	06	07		06	11	11	04	
7.94	08	09		07	13	13	05	
8.0			08					
9.52	09	11	09	09	16	16	06	16
10.0			10					
12.0			12					
12.7	12	15		12	22	22	08	
15.88	16	19	15	15	27	27	10	
16.0			16					
19.05	19	23	19	19	33	33	13	
20.0			20					
25.0			25					
25.4	25	31	25	25	44			
32.0			32					

7. Corner R

8. Hand of Insert

R Right

L Left

9. Chipbreaker

- 41
- 42
- 43
- 45
- 52
- 53

Cutting Condition

Material		Chipbreaker	CVD				
			DC610	DC820	DC9015	DC9025	DC8035
			Cutting speed(m/min)				
Carbon Steel	Low 0.05-0.25% C SM18C	41 43 45	250-700	-	350-500	200-420	180-350
	Medium 0.25-0.55% C SM45C	41 43 46 52	150-350	-	220-380	150-330	120-250
	High 0.55-0.80% C SM55C	43 46 52 53	120-300	-	180-380	120-300	-
Alloy Steel	Low Alloy SCM415	41 43 45	150-550	-	180-350	130-300	60-320
	Alloy SCM440	43 46 52 53	100-320	-	180-350	140-300	60-200
Cast Iron	Grey Cast Iron	46 52 53	100-300	180-440	90-300	-	-
	Ductile Cast Iron		100-250	200-340	90-280	-	-
Stainless Steel		41 42 45	200-270	-	-	-	100-210

Feature of Chipbreaker

Type	Insert • Edge geometry		Feature • Application
NEGATIVE	41		 <ul style="list-style-type: none"> • For medium & finishing • Good chip evacuation in low feed and depth of cut • Excellent chip control
	43		 <ul style="list-style-type: none"> • Balance between strength and sharpness • For semi finishing to medium machining in steel and alloy steel • Good chip control in profiling
	New 46		 <ul style="list-style-type: none"> • Medium for carbon steel and alloy steel • From medium to finishing of cast iron machining • Suitable for continuous to interrupted • Geometry of low cutting force
	52		 <ul style="list-style-type: none"> • Medium in steel and cast Iron • Excellent chip control • Applicable to both interrupted and continuous
	53		 <ul style="list-style-type: none"> • Medium to roughing in steel and cast iron • Strong cutting edge • Recommended for unstable conditions
	42		 <ul style="list-style-type: none"> • For medium machining in stainless steel and low carbon steel • Low cutting force with sharp edge geometry
	45		 <ul style="list-style-type: none"> • For medium machining in stainless steel, low carbon steel & low carbon alloy steel • Semi finishing in cast Iron • Minimum of built-up edge from sharp edge geometry
POSITIVE	51		 <ul style="list-style-type: none"> • Finishing on boring application • Good chip evacuation in low feed and depth of cut • Low cutting force & good chip control
	41		 <ul style="list-style-type: none"> • For semi-finishing to medium machining • Good chip evacuation in low feed and depth of cut • Good chip control
	52		 <ul style="list-style-type: none"> • Medium to roughing in steel and cast iron • Applicable to both interrupted and continuous
	AU		 <ul style="list-style-type: none"> • For aluminum machining • Low cutting force, excellent chip evacuation

Negative 80° Insert

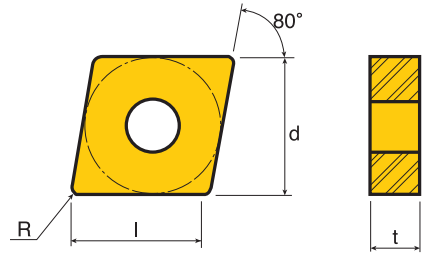





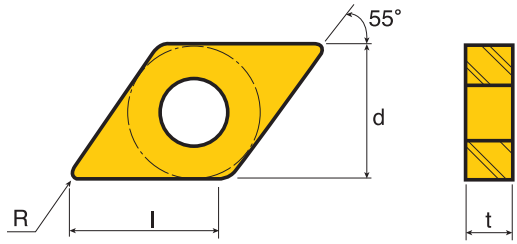

CNM□

Insert	Designation	Dimension(mm)				Recommended cutting condition		Grade					
		l	d	t	R	Feed(mm/rev)	D.O.C(mm)	DC610	DC820	DC9015	DC9025	DC8035	
	CNMA For Cast Iron	CNMA 120404	12.4	12.7	4.76	0.4	0.25 - 0.7	3.0 - 7.0		●			
		120408	12.0	12.7	4.76	0.8	0.25 - 0.7	3.0 - 7.0		●			
		120412	11.6	12.7	4.76	1.2	0.25 - 0.7	3.0 - 7.0		●			
	CNMG 41 Finishing & Medium	CNMG 120404 41	12.4	12.7	4.76	0.4	0.05 - 0.3	0.5 - 2.0	●		●	●	●
		120408 41	12.0	12.7	4.76	0.8	0.07 - 0.3	0.5 - 2.0	●		●	●	●
		120412 41	11.6	12.7	4.76	1.2	0.10 - 0.3	0.5 - 2.0			●	●	
	CNMG 42 For Stainless Steel	CNMG 120404 42	12.4	12.7	4.76	0.4	0.10 - 0.5	0.5 - 5.0					●
		120408 42	12.0	12.7	4.76	0.8	0.12 - 0.5	0.5 - 5.0					●
		120412 42	11.6	12.7	4.76	1.2	0.14 - 0.5	0.5 - 5.0					●
	CNMG 43 Semi finishing & Medium	CNMG 120404 43	12.4	12.7	4.76	0.4	0.12 - 0.52	0.7 - 4.8			●	●	
		120408 43	12.0	12.7	4.76	0.8	0.12 - 0.52	0.7 - 4.8			●	●	
		120412 43	11.6	12.7	4.76	1.2	0.12 - 0.52	0.7 - 4.8			●	●	
	CNMG 45 Medium & Roughing	CNMG 120404 45	12.4	12.7	4.76	0.4	0.15 - 0.5	1.2 - 5.0			●	●	●
		120408 45	12.0	12.7	4.76	0.8	0.15 - 0.5	1.2 - 5.0			●	●	●
		120412 45	11.6	12.7	4.76	1.2	0.15 - 0.5	1.2 - 5.0			●	●	●
	CNMG 46 Medium	CNMG 120404 46	12.4	12.7	4.76	0.4	0.15 - 0.40	1.0 - 5.0			●	●	●
		120408 46	12.0	12.7	4.76	0.8	0.17 - 0.55	1.2 - 5.0		●	●	●	●
		120412 46	11.6	12.7	4.76	1.2	0.20 - 0.55	1.5 - 5.0		●	●	●	●
	CNMG 52 Medium	CNMG 120404 52	12.4	12.7	4.76	0.4	0.09 - 0.35	0.7 - 3.5		●	●	●	
		120408 52	12.0	12.7	4.76	0.8	0.10 - 0.35	0.7 - 3.5		●	●	●	
		120412 52	11.6	12.7	4.76	1.2	0.12 - 0.35	0.7 - 3.5		●	●	●	
	CNMG 53 Medium & Roughing	CNMG 120404 53	12.4	12.7	4.76	0.4	0.22 - 0.6	2.3 - 5.5		●	●	●	
		120408 53	12.0	12.7	4.76	0.8	0.22 - 0.6	2.3 - 5.5		●	●	●	
		120412 53	11.6	12.7	4.76	1.2	0.22 - 0.6	2.3 - 5.5		●	●	●	

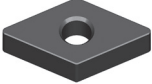
Negative 55° Insert

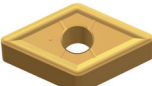

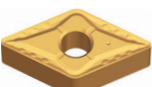
DNM□

Insert	Designation	Dimension(mm)				Recommended cutting condition		Grade				
		l	d	t	R	Feed(mm/rev)	D.O.C(mm)	DC610	DC820	DC9015	DC9025	DC8035
 DNMA For Cast Iron	DNMA 150608	14.7	12.7	6.35	0.8	0.25 - 0.7	3.0 - 7.0		•			
	150612	14.4	12.7	6.35	1.2	0.25 - 0.7	3.0 - 7.0		•			
 DNMG 41 Finishing & Medium	DNMG 150408 41	14.7	12.7	4.76	0.8	0.07 - 0.3	0.5 - 2.0	•		•	•	
	150604 41	15.1	12.7	6.35	0.4	0.05 - 0.3	0.5 - 2.0	•		•	•	
	150608 41	14.7	12.7	6.35	0.8	0.07 - 0.3	0.5 - 2.0	•		•	•	
 DNMG 42 For Stainless Steel	DNMG 150604 42	15.1	12.7	6.35	0.4	0.10 - 0.5	0.5 - 5.0					•
	150608 42	15.1	12.7	6.35	0.8	0.12 - 0.5	0.5 - 5.0					•
	150612 42	14.7	12.7	6.35	1.2	0.14 - 0.5	0.5 - 5.0					•
 DNMG 43 Semi finishing & Medium	DNMG 150604 43	15.1	12.7	6.35	0.4	0.12 - 0.52	0.7 - 4.8			•	•	
	150608 43	15.1	12.7	6.35	0.8	0.12 - 0.52	0.7 - 4.8			•	•	
	150612 43	14.7	12.7	6.35	1.2	0.12 - 0.52	0.7 - 4.8			•	•	
 DNMG 45 Medium & Roughing	DNMG 150604 45	15.1	12.7	6.35	0.4	0.15 - 0.5	1.2 - 5.0			•	•	•
	150608 45	15.1	12.7	6.35	0.8	0.15 - 0.5	1.2 - 5.0			•	•	•
	150612 45	14.7	12.7	6.35	1.2	0.15 - 0.5	1.2 - 5.0			•	•	•
 DNMG 46 Medium	DNMG 150604 46	15.1	12.7	6.35	0.4	0.15 - 0.40	0.8 - 4.0			•	•	•
	150608 46	15.1	12.7	6.35	0.8	0.17 - 0.50	1.0 - 4.0		•	•	•	•
	150612 46	14.7	12.7	6.35	1.2	0.20 - 0.50	1.3 - 4.0		•	•	•	•
 DNMG 52 Medium	DNMG 150404 52	15.1	12.7	4.76	0.4	0.09 - 0.35	0.7 - 3.5				•	
	150408 52	14.7	12.7	4.76	0.8	0.10 - 0.35	0.7 - 3.5				•	
	150604 52	15.1	12.7	6.35	0.4	0.09 - 0.35	0.7 - 3.5		•	•	•	
	150608 52	14.7	12.7	6.35	0.8	0.10 - 0.35	0.7 - 3.5		•	•	•	
	150612 52	14.4	12.7	6.35	1.2	0.12 - 0.35	0.7 - 3.5		•	•	•	
 DNMG 53 Medium & Roughing	DNMG 150604 53	15.1	12.7	6.35	0.4	0.22 - 0.6	2.3 - 5.5		•	•	•	
	150608 53	14.7	12.7	6.35	0.8	0.22 - 0.6	2.3 - 5.5		•	•	•	
	150612 53	14.4	12.7	6.35	1.2	0.22 - 0.6	2.3 - 5.5		•	•	•	

Negative 55° Insert

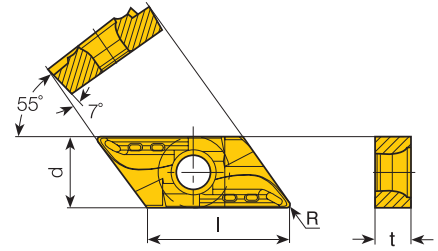

KNMX

Insert	Designation	Dimension(mm)				Recommended cutting condition		Grade			
		l	d	t	R	Feed(mm/rev)	D.O.C(mm)	DC610	DC9015	DC9025	DC8035
	KNMX 160405 LP	19.7	9.52	4.76	0.5	0.15 - 0.35	1.5 - 5.0			•	
	KNMX 160405 RP	19.7	9.52	4.76	0.5	0.15 - 0.35	1.5 - 5.0			•	

Negative 90° Insert

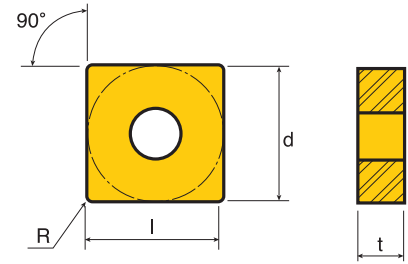





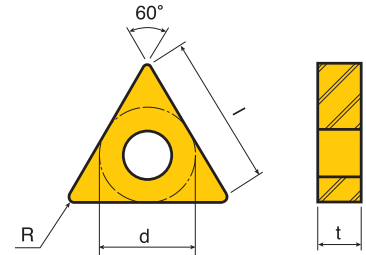

SNM□

Insert	Designation	Dimension(mm)				Recommended cutting condition		Grade				
		l	d	t	R	Feed(mm/rev)	D.O.C(mm)	DC610	DC820	DC9015	DC9025	DC8035
	SNMA 120408	11.9	12.7	4.76	0.8	0.25 - 0.7	3.0 - 7.0		•			
	120412	11.5	12.7	4.76	1.2	0.25 - 0.7	3.0 - 7.0		•			
	SNMG 120404 42	12.3	12.7	4.76	0.4	0.10 - 0.5	0.5 - 5.0					•
	120408 42	11.9	12.7	4.76	0.8	0.12 - 0.5	0.5 - 5.0					•
	120412 42	11.5	12.7	4.76	1.2	0.14 - 0.5	0.5 - 5.0					•
	SNMG 120404 45	12.3	12.7	4.76	0.4	0.15 - 0.5	1.2 - 5.0			•	•	•
	120408 45	11.9	12.7	4.76	0.8	0.15 - 0.5	1.2 - 5.0			•	•	•
	120412 45	11.5	12.7	4.76	1.2	0.15 - 0.5	1.2 - 5.0			•	•	•
	SNMG 120404 46	12.3	12.7	4.76	0.4	0.12 - 0.40	1.0 - 5.0			•	•	•
	120408 46	11.9	12.7	4.76	0.8	0.17 - 0.55	1.2 - 5.0		•	•	•	•
	120412 46	11.5	12.7	4.76	1.2	0.20 - 0.55	1.5 - 5.0		•	•	•	•
	SNMG 120408 52	11.9	12.7	4.76	0.8	0.10 - 0.35	0.7 - 3.5		•	•	•	
	120412 52	11.5	12.7	4.76	1.2	0.12 - 0.35	0.7 - 3.5		•	•	•	
	SNMG 120404 53	12.3	12.7	4.76	0.4	0.22 - 0.6	2.3 - 5.5		•	•	•	
	120408 53	11.9	12.7	4.76	0.8	0.22 - 0.6	2.3 - 5.5		•	•	•	
	120412 53	11.5	12.7	4.76	1.2	0.22 - 0.6	2.3 - 5.5		•	•	•	

Negative 60° Insert





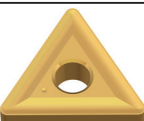

TNM

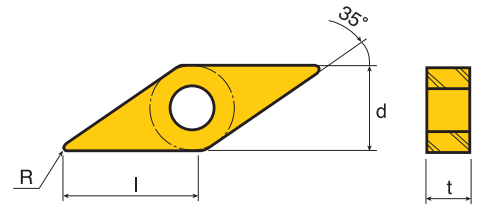
Insert	Designation	Dimension(mm)				Recommended cutting condition		Grade				
		l	d	t	R	Feed(mm/rev)	D.O.C(mm)	DC610	DC820	DC9015	DC9025	DC8035
 TNMA For Cast Iron	TNMA 160404	15.5	9.52	4.76	0.4	0.25 - 0.7	3.0 - 7.0		•			
	160408	14.5	9.52	4.76	0.8	0.25 - 0.7	3.0 - 7.0		•			
	160412	13.5	9.52	4.76	1.2	0.25 - 0.7	3.0 - 7.0		•			
 TNMG 41 Finishing & Medium	TNMG 160404 41	15.5	9.52	4.76	0.4	0.05 - 0.3	0.5 - 2.0	•		•	•	
	160408 41	14.5	9.52	4.76	0.8	0.07 - 0.3	0.5 - 2.0	•		•	•	
 TNMG 42 For Stainless Steel	TNMG 160404 42	15.5	9.52	4.76	0.4	0.10 - 0.5	0.5 - 5.0					•
	160408 42	14.5	9.52	4.76	0.8	0.12 - 0.5	0.5 - 5.0					•
	160412 42	13.5	9.52	4.76	1.2	0.14 - 0.5	0.5 - 5.0					•
 TNMG 43 Semi finishing & Medium	TNMG 160404 43	15.5	9.52	4.76	0.4	0.12 - 0.52	0.7 - 4.8			•	•	
	160408 43	14.5	9.52	4.76	0.8	0.12 - 0.52	0.7 - 4.8			•	•	
	160412 43	13.5	9.52	4.76	1.2	0.12 - 0.52	0.7 - 4.8			•	•	
 TNMG 45 Medium & Roughing	TNMG 160404 45	15.5	9.52	4.76	0.4	0.15 - 0.5	1.2 - 5.0			•	•	•
	160408 45	14.5	9.52	4.76	0.8	0.15 - 0.5	1.2 - 5.0			•	•	•
	160412 45	13.5	9.52	4.76	1.2	0.15 - 0.5	1.2 - 5.0			•	•	•
 TNMG 46 Medium	TNMG 160404 46	15.5	9.52	4.76	0.4	0.17 - 0.40	1.0 - 3.5			•	•	•
	160408 46	14.5	9.52	4.76	0.8	0.17 - 0.50	1.2 - 3.5		•	•	•	•
	160412 46	13.5	9.52	4.76	1.2	0.20 - 0.50	1.5 - 3.5		•	•	•	•
 TNMG 52 Medium	TNMG 160404 52	15.5	9.52	4.76	0.4	0.09 - 0.35	0.7 - 3.5		•	•	•	
	160408 52	14.5	9.52	4.76	0.8	0.10 - 0.35	0.7 - 3.5		•	•	•	
 TNMG 53 Medium & Roughing	TNMG 160404 53	15.5	9.52	4.76	0.4	0.22 - 0.6	2.3 - 5.5		•	•	•	
	160408 53	14.5	9.52	4.76	0.8	0.22 - 0.6	2.3 - 5.5		•	•	•	
	160412 53	13.5	9.52	4.76	1.2	0.22 - 0.6	2.3 - 5.5		•	•	•	

Negative 35° Insert



VNMG

Insert	Designation	Dimension(mm)				Recommended cutting condition		Grade				
		l	d	t	R	Feed(mm/rev)	D.O.C(mm)	DC610	DC820	DC9015	DC9025	DC8035
 VNMG 41 Finishing & Medium	VNMG 160404 41	15.6	9.52	4.76	0.4	0.05 - 0.3	0.5 - 2.0	●		●	●	
	VNMG 160408 41	14.6	9.52	4.76	0.8	0.07 - 0.3	0.5 - 2.0	●		●	●	
 VNMG 45 Medium & Roughing	VNMG 160404 45	15.6	9.52	4.76	0.4	0.15 - 0.5	1.2 - 5.0			●	●	●
	VNMG 160408 45	14.6	9.52	4.76	0.8	0.15 - 0.5	1.2 - 5.0			●	●	●
	VNMG 160412 45	13.6	9.52	4.76	1.2	0.15 - 0.5	1.2 - 5.0			●	●	●
 VNMG 46 Medium	VNMG 160404 46	15.6	9.52	4.76	0.4	0.15 - 0.36	0.8 - 3.0			●	●	●
	VNMG 160408 46	14.6	9.52	4.76	0.8	0.17 - 0.36	1.0 - 2.5		●	●	●	●
	VNMG 160412 46	13.6	9.52	4.76	1.2	0.20 - 0.36	1.2 - 2.5		●	●	●	●
 VNMG 53 Medium & Roughing	VNMG 160404 53	15.6	9.52	4.76	0.4	0.22 - 0.6	2.3 - 5.5		●	●	●	
	VNMG 160408 53	14.6	9.52	4.76	0.8	0.22 - 0.6	2.3 - 5.5		●	●	●	
	VNMG 160412 53	13.6	9.52	4.76	1.2	0.22 - 0.6	2.3 - 5.5		●	●	●	

Negative 80° Insert

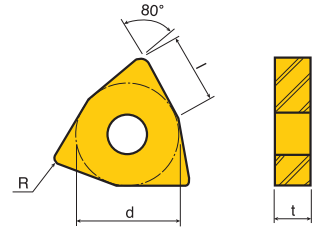



WNM□

Insert	Designation	Dimension(mm)				Recommended cutting condition		Grade				
		l	d	t	R	Feed(mm/rev)	D.O.C(mm)	DC610	DC820	DC9015	DC9025	DC8035
	WNMA 080408	8.3	12.7	4.76	0.8	0.25 - 0.7	3.0 - 7.0		•			
	080412	8.2	12.7	4.76	1.2	0.25 - 0.7	3.0 - 7.0		•			
	WNMG 080408 41	8.3	12.7	4.76	0.8	0.07 - 0.3	0.5 - 2.0	•		•	•	•
	080412 41	8.3	12.7	4.76	1.2	0.10 - 0.3	0.5 - 2.0	•		•	•	
	WNMG 080404 42	8.4	12.7	4.76	0.4	0.10 - 0.5	0.5 - 5.0					•
	080408 42	8.3	12.7	4.76	0.8	0.12 - 0.5	0.5 - 5.0					•
	080412 42	8.2	12.7	4.76	1.2	0.14 - 0.5	0.5 - 5.0					•
	WNMG 080404 43	8.4	12.7	4.76	0.4	0.12 - 0.52	0.7 - 4.8			•	•	
	080408 43	8.3	12.7	4.76	0.8	0.12 - 0.52	0.7 - 4.8			•	•	
	080412 43	8.2	12.7	4.76	1.2	0.12 - 0.52	0.7 - 4.8			•	•	
	WNMG 060404 45	6.2	9.52	4.76	0.4	0.15 - 0.5	1.2 - 5.0			•	•	•
	060408 45	6.1	9.52	4.76	0.8	0.15 - 0.5	1.2 - 5.0			•	•	•
	060412 45	6.0	9.52	4.76	1.2	0.15 - 0.5	1.2 - 5.0			•	•	•
	080404 45	8.4	12.7	4.76	0.4	0.15 - 0.5	1.2 - 5.0			•	•	•
	080408 45	8.3	12.7	4.76	0.8	0.15 - 0.5	1.2 - 5.0			•	•	•
080412 45	8.2	12.7	4.76	1.2	0.15 - 0.5	1.2 - 5.0			•	•	•	
	WNMG 080404 46	8.4	12.7	4.76	0.4	0.12 - 0.40	1.0 - 4.0			•	•	•
	080408 46	8.3	12.7	4.76	0.8	0.17 - 0.55	1.2 - 4.0		•	•	•	•
	080412 46	8.2	12.7	4.76	1.2	0.25 - 0.55	1.5 - 4.0		•	•	•	•
	WNMG 080404 52	8.3	12.7	4.76	0.4	0.09 - 0.35	0.7 - 3.5		•	•	•	
	080408 52	8.3	12.7	4.76	0.8	0.10 - 0.35	0.7 - 3.5		•	•	•	•
	080412 52	8.3	12.7	4.76	1.2	0.12 - 0.35	0.7 - 3.5		•			

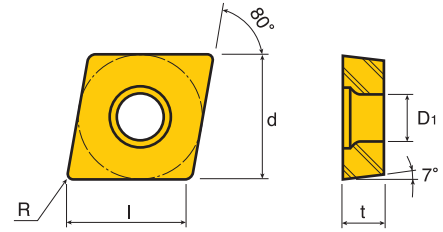
Positive 80° Insert

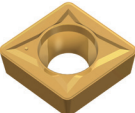

CCMT

Insert	Designation	Dimension(mm)						Recommended cutting condition		Grade			
		l	d	t	R	ØD1	Feed(mm/rev)	D.O.C(mm)	DC610	DC820	DC9015	DC9025	
 CCMT 41 Finishing & Medium	CCMT 060204 41	6.0	6.35	2.38	0.4	2.8	0.05 - 0.15	0.5 - 2.5	●		●	●	
	09T304 41	9.2	9.52	3.97	0.4	4.4	0.05 - 0.15	0.5 - 2.5	●		●	●	
	09T308 41	8.8	9.52	3.97	0.8	4.4	0.07 - 0.15	0.5 - 2.5				●	
 CCMT 51 Finishing	CCMT 09T304 51	9.2	9.52	3.97	0.4	4.4	0.05 - 0.15	0.5 - 2.5			●	●	
	09T308 51	8.8	9.52	3.97	0.8	4.4	0.07 - 0.15	0.5 - 2.5			●	●	
 CCMT 52 Medium	CCMT 09T304 52	9.2	9.52	3.97	0.4	4.4	0.07 - 0.25	1.0 - 3.0		●	●	●	
	09T308 52	8.8	9.52	3.97	0.8	4.4	0.09 - 0.25	1.0 - 3.0		●	●	●	

Positive 55° Insert

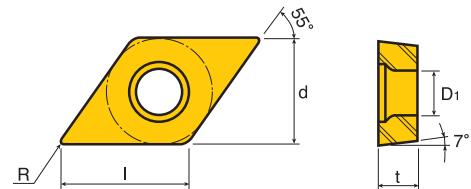

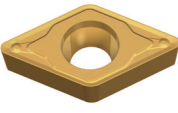
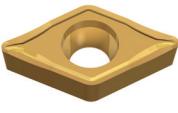
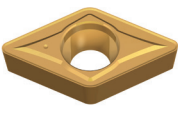

DCMT

Insert	Designation	Dimension(mm)						Recommended cutting condition		Grade			
		l	d	t	R	ØD1	Feed(mm/rev)	D.O.C(mm)	DC610	DC820	DC9015	DC9025	
 DCMT 41 Finishing & Medium	DCMT 070204 41	7.3	6.35	2.38	0.4	2.8	0.05 - 0.15	0.5 - 2.5	●		●	●	
	11T304 41	11.2	9.52	3.97	0.4	4.4	0.05 - 0.15	0.5 - 2.5	●		●	●	
	11T308 41	10.8	9.52	3.97	0.8	4.4	0.07 - 0.15	0.5 - 2.5	●		●	●	
 DCMT 51 Finishing	DCMT 11T304 51	11.2	9.52	3.97	0.4	4.4	0.05 - 0.15	0.5 - 2.5			●	●	
	11T308 51	10.8	9.52	3.97	0.8	4.4	0.07 - 0.15	0.5 - 2.5			●	●	
 DCMT 52 Medium	DCMT 11T304 52	11.2	9.52	3.97	0.4	4.4	0.07 - 0.25	1.0 - 3.0		●	●	●	
	11T308 52	10.8	9.52	3.97	0.8	4.4	0.09 - 0.25	1.0 - 3.0		●	●	●	
	11T312 52	10.5	9.52	3.97	1.2	4.4	0.10 - 0.25	1.0 - 3.0		●	●	●	

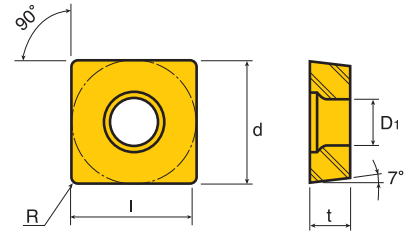
Positive 90° Insert





SCMT

Insert	Designation	Dimension(mm)					Recommended cutting condition		Grade			
		l	d	t	R	ØD ₁	Feed(mm/rev)	D.O.C(mm)	DC610	DC820	DC9015	DC9025
 SCMT 51 Finishing	SCMT 09T304 51	9.2	9.52	3.97	0.4	4.4	0.05 - 0.15	0.5 - 2.5			●	●
	09T308 51	8.7	9.52	3.97	0.8	4.4	0.07 - 0.15	0.5 - 2.5			●	●
 SCMT 52 Medium	SCMT 09T304 52	9.2	9.52	3.97	0.4	4.4	0.07 - 0.25	1.0 - 3.0		●	●	●
	09T308 52	9.2	9.52	3.97	0.4	4.4	0.09 - 0.25	1.0 - 3.0		●	●	●

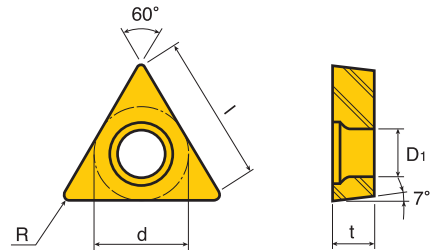
Positive 60° Insert



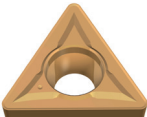

TCMT

Insert	Designation	Dimension(mm)					Recommended cutting condition		Grade			
		l	d	t	R	ØD ₁	Feed(mm/rev)	D.O.C(mm)	DC610	DC820	DC9015	DC9025
 TCMT 41 Finishing & Medium	TCMT 110204 41	10.0	6.35	2.38	0.4	2.8	0.05 - 0.15	0.5 - 2.5			●	●
 TCMT 51 Finishing	TCMT 16T304 51	15.5	9.52	3.97	0.4	4.4	0.05 - 0.15	0.5 - 2.5			●	●
	16T308 51	14.5	9.52	3.97	0.8	4.4	0.07 - 0.15	0.5 - 2.5			●	●
 TCMT 52 Medium	TCMT 16T304 52	15.5	9.52	3.97	0.4	4.4	0.07 - 0.25	1.0 - 3.0		●	●	●
	16T308 52	14.5	9.52	3.97	0.8	4.4	0.09 - 0.25	1.0 - 3.0		●	●	●
	16T312 52	13.5	9.52	3.97	1.2	4.4	0.10 - 0.25	1.0 - 3.0		●	●	●

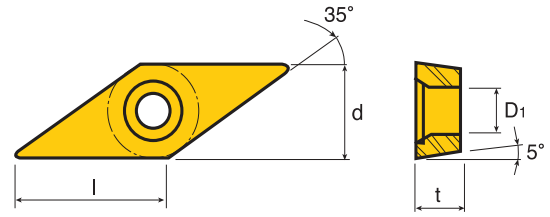
Positive 35° Insert

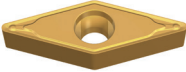

VBMT

Insert	Designation	Dimension(mm)						Recommended cutting condition		Grade			
		l	d	t	R	ØD ₁	Feed(mm/rev)	D.O.C(mm)	DC610	DC820	DC9015	DC9025	
 VBMT 41 Finishing & Medium	VBMT 160404 41	15.6	9.52	4.76	0.4	4.4	0.05 - 0.15	0.5 - 2.5	●		●	●	
	160408 41	14.6	9.52	4.76	0.8	4.4	0.07 - 0.15	0.5 - 2.5	●		●	●	
 VBMT 51 Finishing	VBMT 160404 51	15.6	9.52	4.76	0.4	4.4	0.05 - 0.15	0.5 - 2.5			●	●	
	160408 51	14.6	9.52	4.76	0.8	4.4	0.07 - 0.15	0.5 - 2.5			●	●	
 VBMT 52 Medium	VBMT 160404 52	15.6	9.52	4.76	0.4	4.4	0.07 - 0.25	1.0 - 3.0		●	●	●	
	160408 52	14.6	9.52	4.76	0.8	4.4	0.09 - 0.25	1.0 - 3.0		●	●	●	
	160412 52	13.6	9.52	4.76	1.2	4.4	0.10 - 0.25	1.0 - 3.0		●	●	●	

Positive 80° Insert - For Aluminum

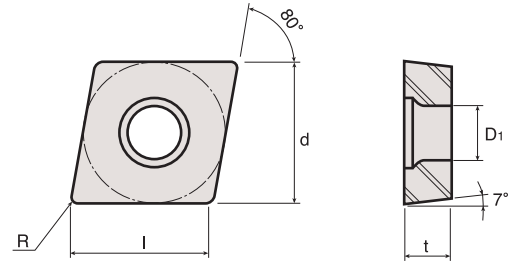

CCGT AU

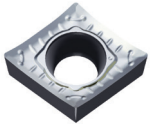

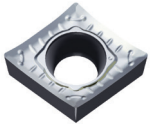
Insert	Designation	Dimension(mm)					Grade	
		l	d	t	R	ØD ₁	DC210	
	CCGT 060202 AU	6.0	6.35	2.38	0.2	2.8	•	
	060204 AU	6.0	6.35	2.38	0.4	2.8	•	
	09T302 AU	9.2	9.52	3.97	0.2	4.4	•	
	09T304 AU	9.2	9.52	3.97	0.4	4.4	•	
	09T308 AU	9.2	9.52	3.97	0.8	4.4	•	
	120404 AU	12.4	12.7	4.76	0.4	5.5	•	
	120408 AU	12.4	12.7	4.76	0.8	5.5	•	

Positive 55° Insert - For Aluminum

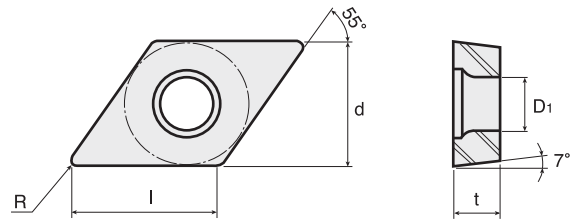

DCGT AU

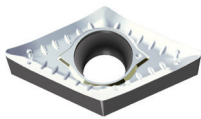

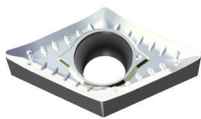
Insert	Designation	Dimension(mm)					Grade	
		l	d	t	R	ØD ₁	DC210	
	DCGT 070202 AU	7.5	6.35	2.38	0.2	2.8	•	
	070204 AU	7.3	6.35	2.38	0.4	2.8	•	
	11T302 AU	11.4	9.525	3.97	0.2	4.4	•	
	11T304 AU	11.4	9.525	3.97	0.4	4.4	•	
	11T308 AU	11.2	9.525	3.97	0.8	4.4	•	

Positive 90° Insert - For Aluminum

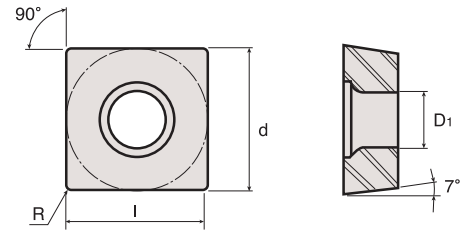

SCGT AU

Insert	Designation	Dimension(mm)					ØD ₁	Grade
		l	d	t	R			
	SCGT 120404 AU	12.3	12.70	4.76	0.4		5.5	•
	120408 AU	11.9	12.70	4.76	0.8		5.5	•

Positive 60° Insert - For Aluminum

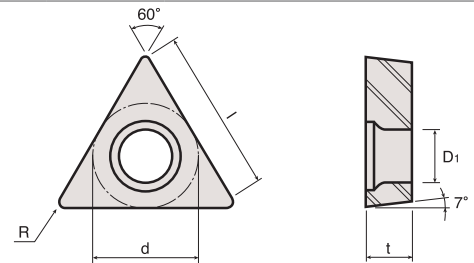

TCGT AU

Insert	Designation	Dimension(mm)					ØD ₁	Grade
		l	d	t	R			
	TCGT 110204 AU	10.0	6.35	2.38	0.4		2.8	•
	16T304 AU	15.5	9.525	3.97	0.4		4.4	•
	16T308 AU	15.5	9.525	3.97	0.8		4.4	•

Positive 35° Insert - For Aluminum

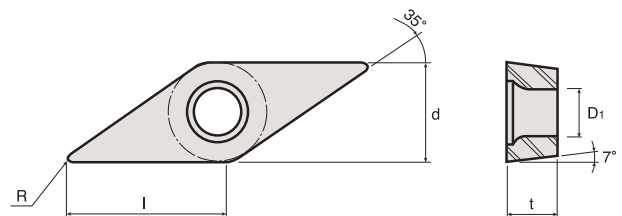

VCGT AU

Insert	Designation	Dimension(mm)					ØD ₁	Grade
		l	d	t	R			
	VCGT 110302 AU	10.0	6.35	3.18	0.2		2.8	•
	110304 AU	10.0	6.35	3.18	0.4		2.8	•
	160404 AU	15.6	9.52	4.76	0.4		4.4	•
	160408 AU	14.6	9.52	4.76	0.8		4.4	•

Designation System of External Holder

1. Clamping System

- P / Lever
- C / Top Clamp
- S / Screw Clamp
- M / Multi Lock
- W / Wedge Clamp

2. Insert Shape

- 80°
C
- 55°
D
- 55°
K
- R
- S
- T
- 35°
V

4. Insert Clearance Angle

- 0°
N
- 5°
B
- 7°
C
- 11°
P

P C L N R

1 2 3 4 5

3. Approach Angle

Symbol	Shape	Offset	Symbol	Shape	Offset	Symbol	Shape	Offset
A	90°	x	J	93°	○	V	72.5°	x
	90°		K	75°	○	W	60°	○
B	75°	x	L	95°	○	X	Special	
			M	50°	x			
D	45°	x	N	63°	x			
E	60°	x	R	75°	○			
F	90°	○	S	45°	○			
G	90°	○	T	60°	○			
	90°		U	93°	○			

5. Hand of Tool

- Right-R**
- Neutral-N**
- Left-L**

6. Shank Height

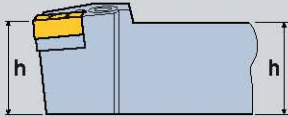

Integers to be preceded by 0
e.g.: h=8=mm indicated by 08

7. Shank Width

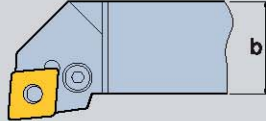

Integers to be preceded by 0
e.g.: b=8=mm indicated by 08

8. Tool Length

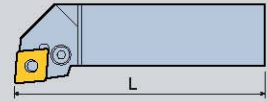

L (mm)	Symbol	L (mm)	Symbol
32	A	160	N
40	B	170	P
50	C	180	Q
60	D	200	R
70	E	250	S
80	F	300	T
90	G	350	U
100	H	400	V
110	J	450	W
125	K	500	Y
140	L	Special	X
150	M		

25 **25** **M** **12** -

6 7 8 9 10

9. Cutting Edge Length

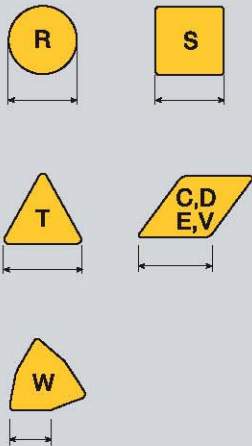

10. Manufacturer's Type

Unique to manufacturer

CKJNR/L

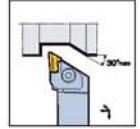
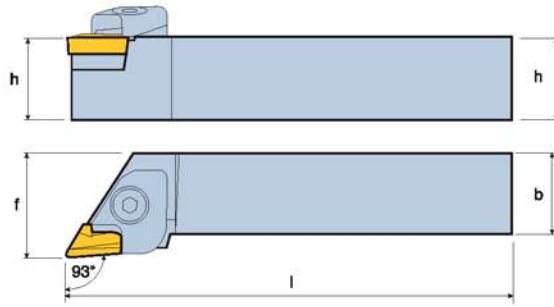
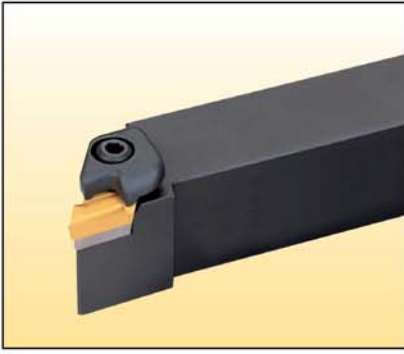

Designation	Dimension (mm)				Insert
	h	b	l	f	
CKJNR/L 2020 K16	20	20	125	25	 KNUX 16 R/L 11 KNUX 16 R/L 12
2525 M16	25	25	150	32	
3232 P16	32	32	170	40	

Holder/ Related insert	Component						
	Clamp	Screw	Clamp Spring	Pin & Spring	Shim	Shim Screw	Wrench
2020...16							
2525...16	DCC 16KR/L	DCS 16K	DCS 90	DPS 48 DP 48S	DCS-K 1604R/L	* DSP16K	DHLW- 4
3232...16						FH M3 X 0.5 X 10	

Insert page: 12

* DSP16K is a shim pin.

MVJNR/L

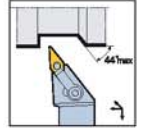
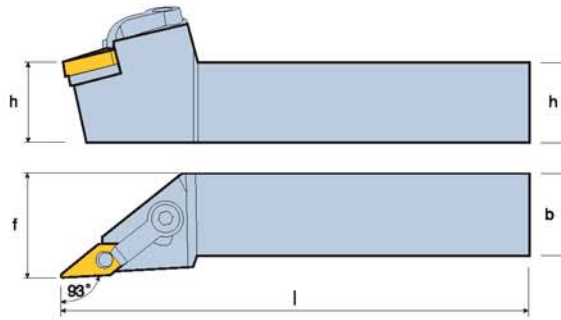
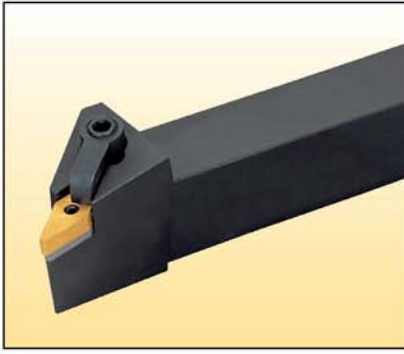

Designation	Dimension (mm)				Insert
	h	b	l	f	
MVJNR/L 2525 M16	25	25	150	32	VN□□ 1604 □□

Holder/ Related insert	Component				
	Clamp	Screw	Shim	Lock Pin	Wrench
...16	DMC 30	DNSM 0825	DMS-V 324	DLP 3	DHLW-2, DHLW-4

Insert page: 15

MVQNR/L

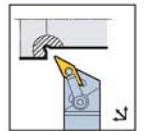
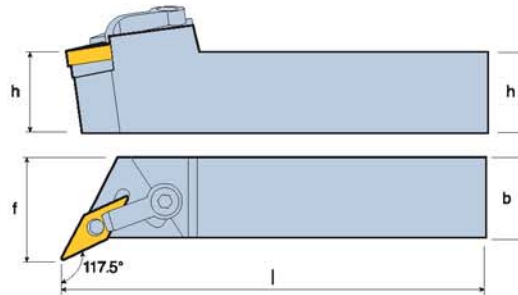

Designation	Dimension (mm)				Insert
	h	b	l	f	
MVQNR/L 2525 M16	25	25	150	32	VN□□ 1604 □□

Holder/ Related insert	Component				
	Clamp	Screw	Shim	Lock Pin	Wrench
...16	DMC 30	DNSM 0825	DMS-V 324	DLP 3	DHLW-2, DHLW-4

Insert page: 15

MVVNN

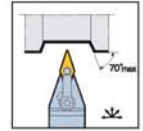
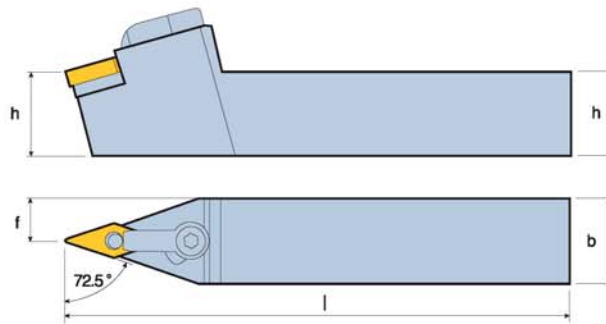
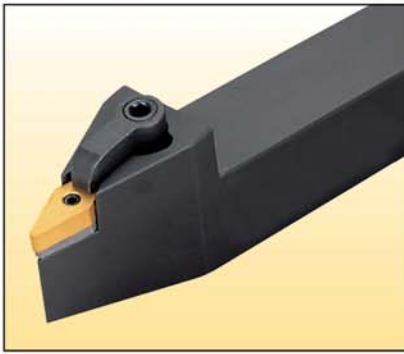

Designation	Dimension (mm)				Insert
	h	b	l	f	
MVVNN 2020 K16	20	20	125	10.0	VN □ □ 1604 □ □
	2525 M16	25	25	150	

Holder/ Related insert	Component				
	Clamp	Screw	Shim	Lock Pin	Wrench
...16	DMC 30	DNSM 0825	DMS-V 324	DLP 3	DHLW-2, DHLW-4

Insert page: 15

PCBNR/L

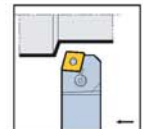
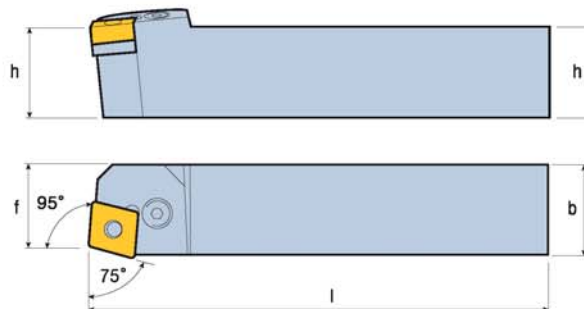
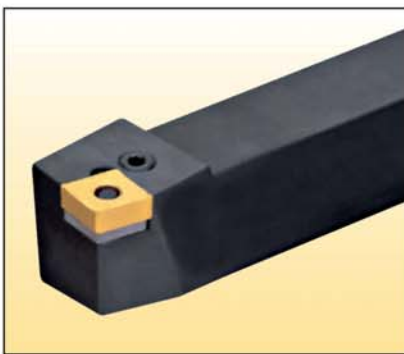

Designation	Dimension (mm)				Insert	
	h	b	l	f		
PCBNR/L 2020 K12	20	20	125	17.5	CN □ □ 1204 □ □	
	2525 M12	25	25	150		22.5
	3225 P12	32	25	170		22.5

Holder/ Related insert	Component				
	Lever	Screw	Shim	Shim Pin	Wrench
...12	DLC 4	DLCS 4	DLS-C 42	DSP 4	DHLW-3

Insert page: 11

PCLNR/L

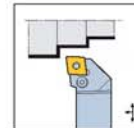
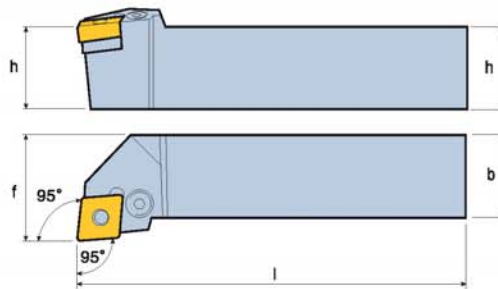
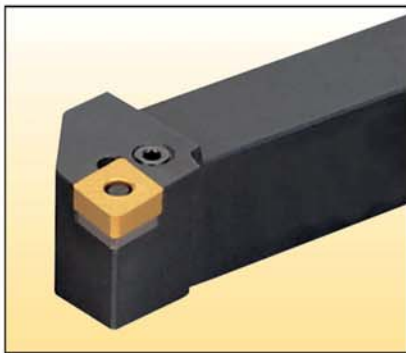

Designation	Dimension (mm)				Insert
	h	b	l	f	
PCLNR/L 1616 H12	16	16	100	20	 CN□□ 1204 □□ <hr/> CN□□ 1906 □□
2020 K12	20	20	125	25	
2525 M12	25	25	150	32	
3225 P12	32	25	170	32	
3232 P12	32	32	170	40	
3232 P19	32	32	170	40	

Holder/ Related insert	Component				
	Lever	Screw	Shim	Shim Pin	Wrench
...12					
...12	DLC 4	DLCS 4	DLS-C 42	DSP 4	DHLW-3
...19	DLC 6	DLCS 6	DLS-C 63	DSP 6	DHLW-4

Insert page: 11

PDJNR/L

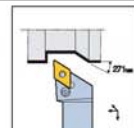
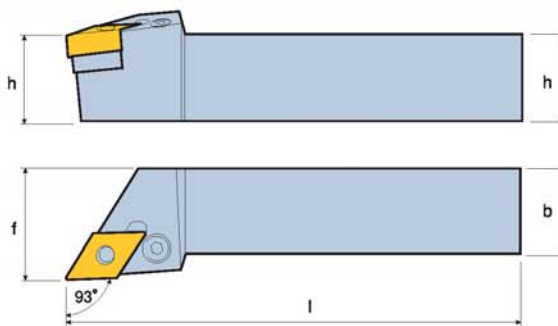

Designation	Dimension (mm)				Insert
	h	b	l	f	
PDJNR/L 2020 K15	20	20	125	25	 DN□□ 1506 □□
2525 M15	25	25	150	32	
3232 P15	32	32	170	40	

Holder/ Related insert	Component				
	Lever	Screw	Shim	Shim Pin	Wrench
...15					
...15	DLC 4A	DLCS 4	DLS-D 42	DSP 4	DHLW-3

Insert page: 12

PDNNR/L

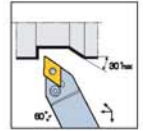
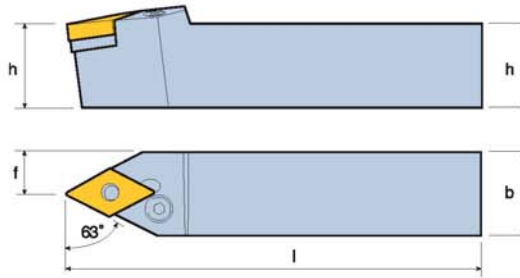
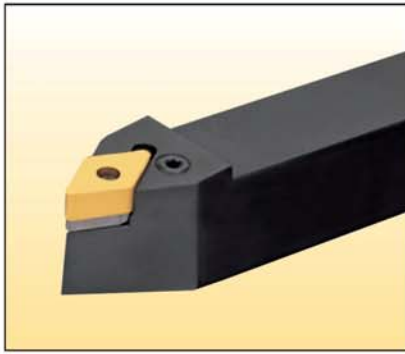

Designation	Dimension (mm)				Insert
	h	b	l	f	
PDNNR/L 2525 M15	25	25	150	18.5	 DN□□ 1506 □□
3232 P15	32	32	170	23.4	

Holder/ Related insert	Component				
	Lever	Screw	Shim	Shim Pin	Wrench
...15	DLC 4A	DLCS 4	DLS-D 42	DSP 4	DHLW-3

Insert page: 12

PSBNR/L

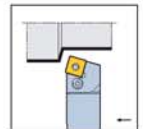
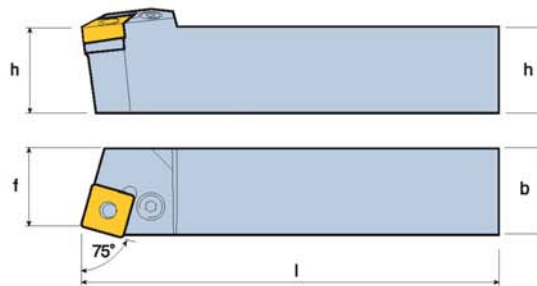
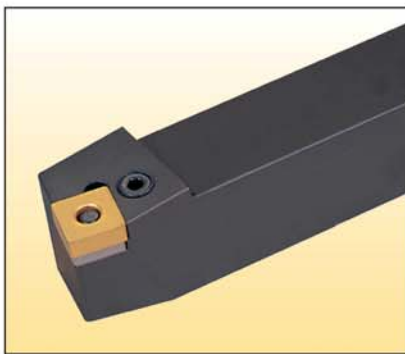

Designation	Dimension (mm)				Insert
	h	b	l	f	
PSBNR/L 2020 K12	20	20	125	17	 SN□□ 1204 □□
2525 M12	25	25	150	22	

Holder/ Related insert	Component				
	Lever	Screw	Shim	Shim Pin	Wrench
...12	DLC 4	DLCS 4	DLS-S 42	DSP 4	DHLW-3

Insert page: 13

PSDNN

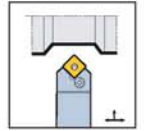
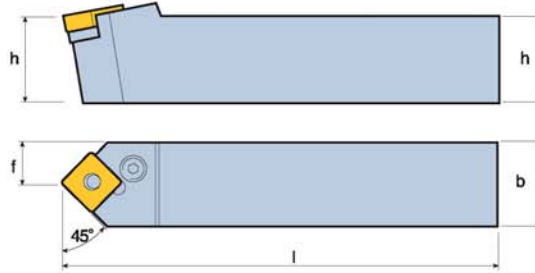
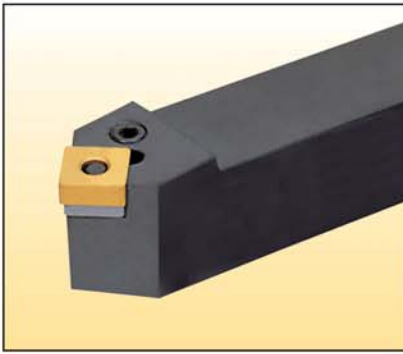

Designation	Dimension (mm)				Insert	
	h	b	l	f		
PSDNN	2020 K12	20	20	125	10.0	SN □ □ 1204 □ □
	2525 M12	25	25	150	12.5	
	3225 P12	32	25	170	12.5	

Holder/ Related insert	Component				
	Lever	Screw	Shim	Shim Pin	Wrench
...12	DLC 4	DLCS 4	DLS-S 42	DSP 4	DHLW-3

Insert page: 13

PSKNR/L

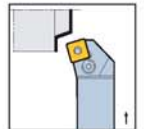
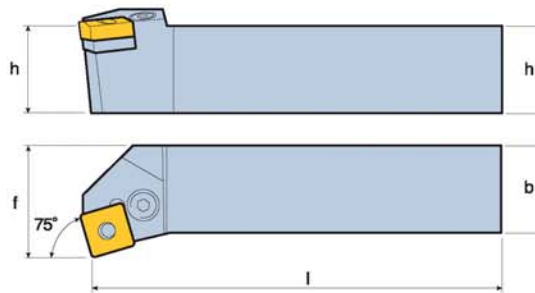
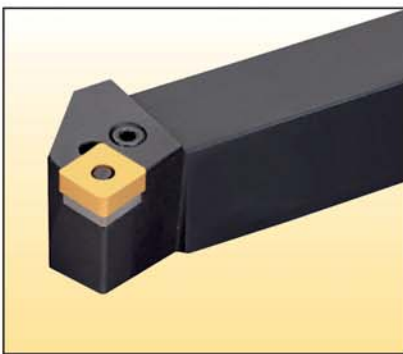

Designation	Dimension (mm)				Insert	
	h	b	l	f		
PSKNR/L	2525 M12	25	25	150	32	SN □ □ 1204 □ □

Holder/ Related insert	Component				
	Lever	Screw	Shim	Shim Pin	Wrench
...12	DLC 4	DLCS 4	DLS-S 42	DSP 4	DHLW-3

Insert page: 13

PSSNR/L

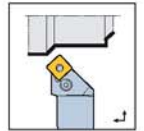
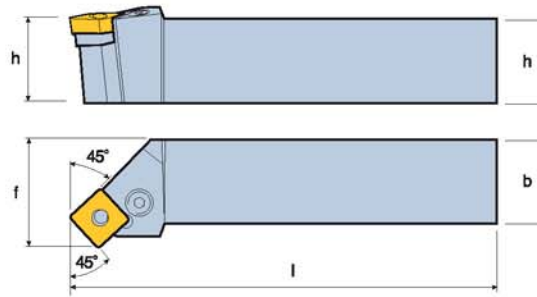
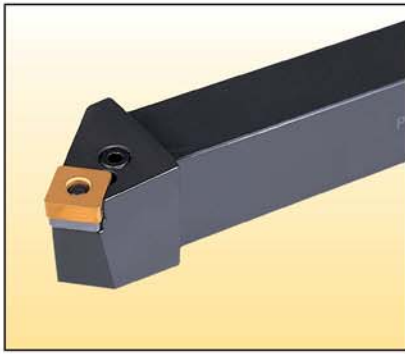

Designation	Dimension (mm)					Insert
	h	b	l	f		
PSSNR/L 2020 K12	20	20	125	25		SN□□ 1204 □□
2525 M12	25	25	150	32		
Holder/ Related insert	Component					
	Lever	Screw	Shim	Shim Pin	Wrench	
...12	DLC 4	DLCS 4	DLS-S 42	DSP 4	DHLW-3	

Insert page: 13

PTFNR/L

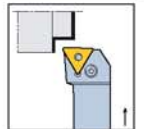
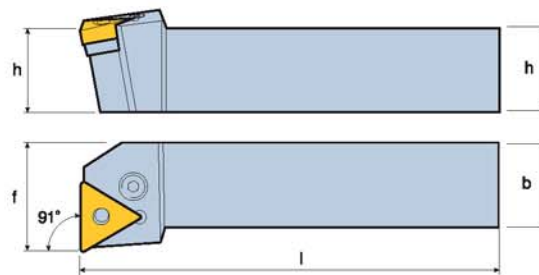
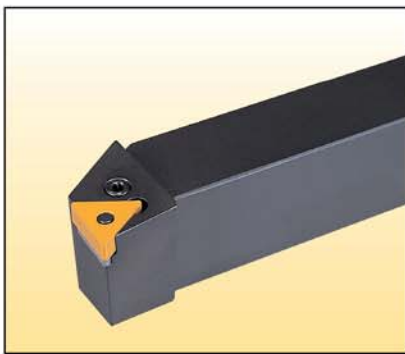

Designation	Dimension (mm)					Insert
	h	b	l	f		
PTFNR/L 2020 K16	20	20	125	25		TN□□ 1604 □□
2525 M16	25	25	150	32		
Holder/ Related insert	Component					
	Lever	Screw	Shim	Shim Pin	Wrench	
...16	DLC 3	DLCS 3	DLS-T 31.8	DSP 3A	DHLW-2.5	

Insert page: 14

PTGNR/L

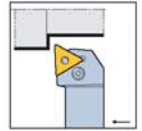
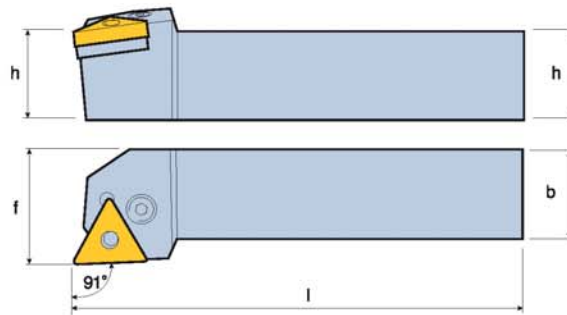
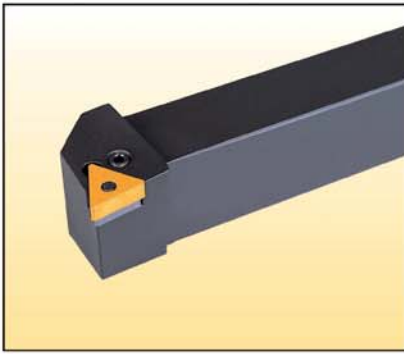

Designation	Dimension (mm)				Insert	
	h	b	l	f		
PTGNR/L	1616 H16	16	16	100	20	TN □ □ 1604 □ □
	2020 K16	20	20	125	25	
	2525 M16	25	25	150	32	

Holder/ Related insert	Component				
	Lever	Screw	Shim	Shim Pin	Wrench
...16	DLC 3	DLCS 3	DLS-T 31.8	DSP 3A	DHLW-2.5

Insert page: 14

SCLCR/L

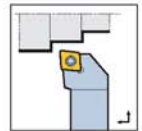
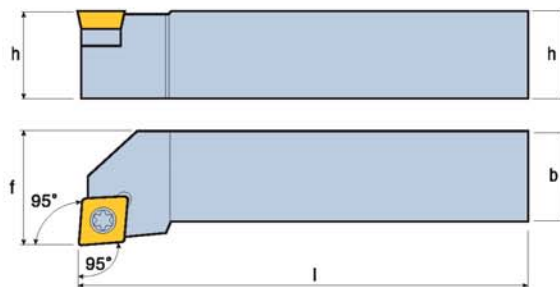
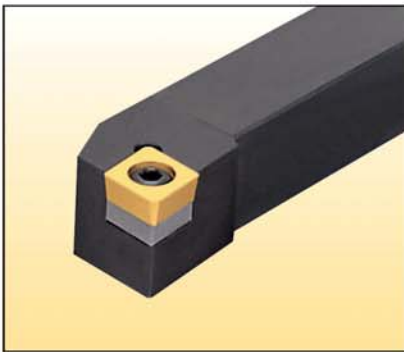

Designation	Dimension (mm)				Insert	
	h	b	l	f		
SCLCR/L	1212 F09	12	12	80	16	CC □ □ 09T3 □ □ CC □ □ 1204 □ □
	1616 H09	16	16	100	20	
	2020 K09	20	20	125	25	
	2525 M09	25	25	150	32	
	2020 K12	20	20	125	25	
	2020 M12	20	20	150	32	

Holder/ Related insert	Component			
	Screw	Shim	Shim Screw	Wrench
1212...09	DS 35080I	-	-	DTFW-15
1616...09	DS 35124I	DSS-C 32	DSC 50090S	DTFW-15
2020...09				
2525...09	DS 45130I	DSS-C 43N	DSC 60105S	DTFW-20
2020...12				

Insert pages: 18, 20

SDJCR/L

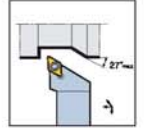
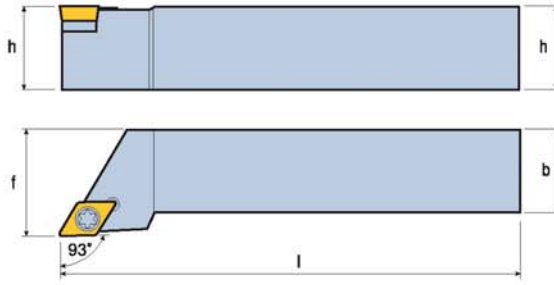
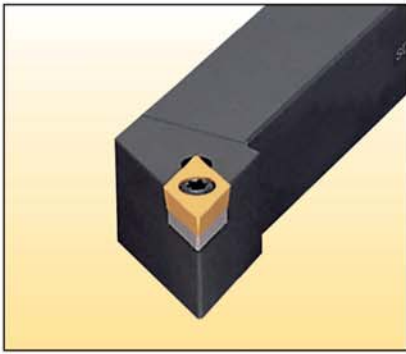

Designation	Dimension (mm)				Insert
	h	b	l	f	
SDJCR/L 1616 H11	16	16	100	20	 DC□□11T3□□
2020 K11	20	20	125	25	
2525 M11	25	25	150	32	

Holder/ Related insert	Component			
	Screw	Shim	Shim Screw	Wrench
...11	DS 35124I	DSS-D 32	DSC 50090S	DTFW-15

Insert pages: 18, 20

SSDCN

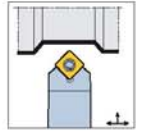
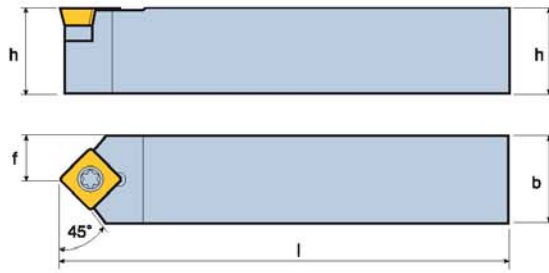

Designation	Dimension (mm)				Insert	
	h	b	l	f		
SSDCN	1212 F09	12	12	80	6	SC□□ 09T3 □□
	1616 H09	16	16	100	8	

Holder/ Related insert	Component			
	Screw	Shim	Shim Screw	Wrench
1212...09	DS 35080I	-	-	DTFW-15
1616...09	DS 35124I	DSS-S 32	DSC 50090S	DTFW-15

Insert page: 19

STGCR/L

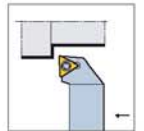
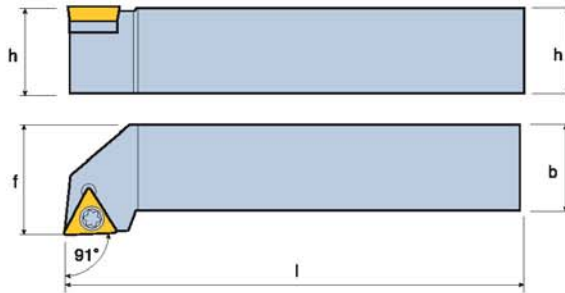
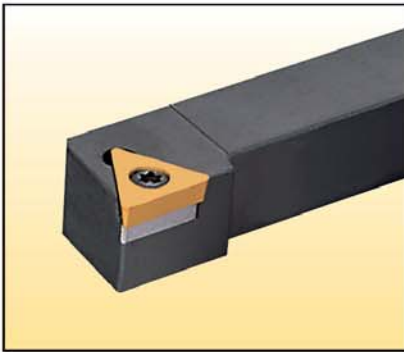

Designation	Dimension (mm)				Insert	
	h	b	l	f		
STGCR/L	1616 H16	16	16	100	20	TC□□ 16T3 □□
	2020 K16	20	20	125	25	
	2525 M16	25	25	150	32	

Holder/ Related insert	Component			
	Screw	Shim	Shim Screw	Wrench
...16	DS 35124I	DSS-T 32	DSC 50090S	DTFW-15

Insert pages: 19, 21

SVJBR/L

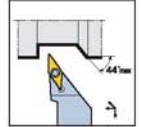
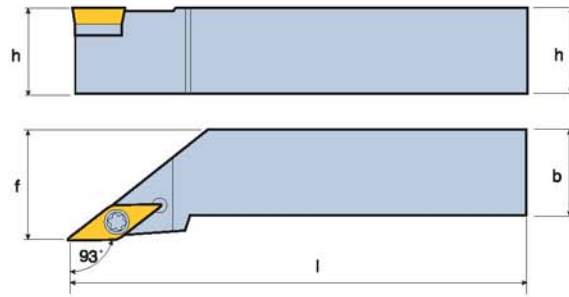
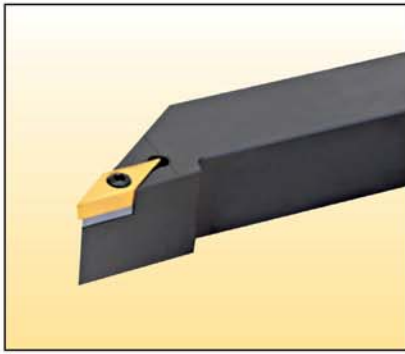

Designation	Dimension (mm)				Insert
	h	b	l	f	
SVJBR/L 2020 K16	20	20	125	25	VB □ 1604 □ □
2525 M16	25	25	150	32	

Holder/ Related insert	Component			
	Screw	Shim	Shim Screw	Wrench
...16	 DS 35124I	 DSS-V 32	 DS 5035062S-TS	 DTFW-15

Insert page: 16

SVJCR/L

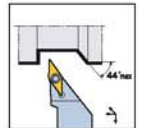
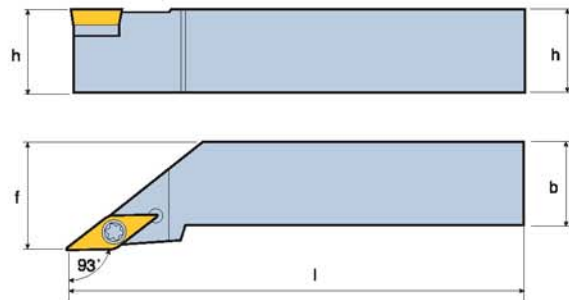
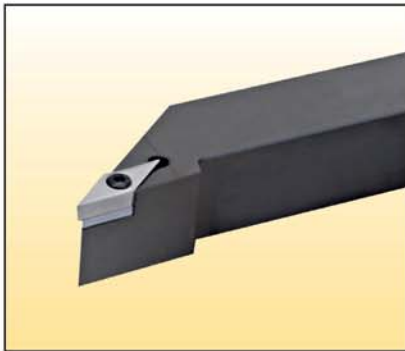

Designation	Dimension (mm)				Insert
	h	b	l	f	
SVJCR/L 2020 K16	20	20	125	25	VCG □ 1604 □ □
2525 M16	25	25	150	32	

Holder/ Related insert	Component			
	Screw	Shim	Shim Screw	Wrench
...16	 DS 35124I	 DSS-V 32	 DSC 50090S	 DTFW-15

Insert page: 21

SVVBN

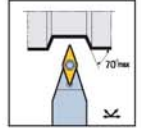
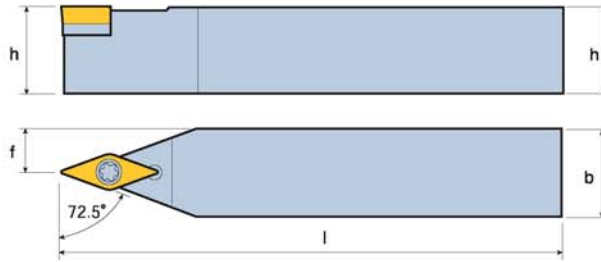
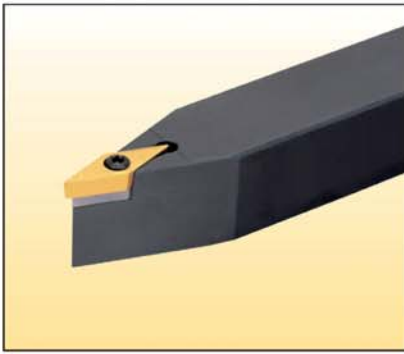

Designation	Dimension (mm)				Insert
	h	b	l	f	
SVVBN 2020 K16	20	20	125	10.0	VB □ □ 1604 □ □
	2525 M16	25	25	150	

Holder/ Related insert	Component			
	Screw	Shim	Shim Screw	Wrench
...16	DS 35124I	DSS-V 32	DSC 50090S	DTFW-15

Insert page: 16

WTENN

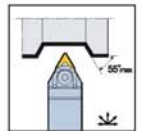
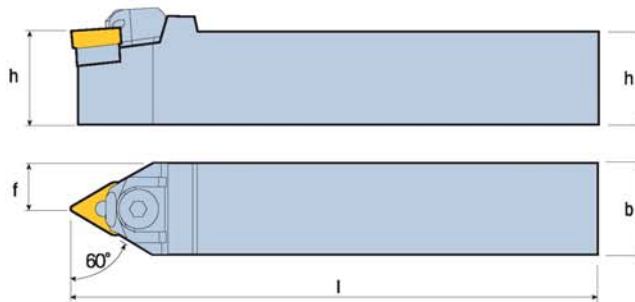
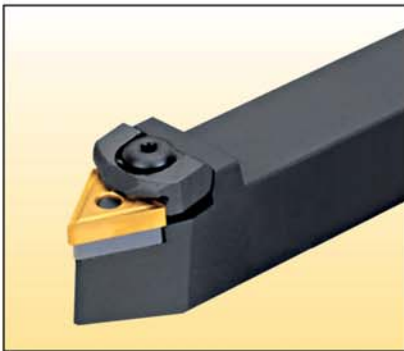

Designation	Dimension (mm)				Insert	
	h	b	l	f		
WTENN 2020 K16	20	20	125	10.0	TN □ □ 1604 □ □ TN □ □ 2204 □ □	
	2525 M16	25	25	150		12.5
	2525 M22	25	25	150		12.5

Holder/ Related insert	Component					
	Wedge Clamp	Screw	Snap Ring	Shim	Pin Screw	Wrench
...16	DWC 33	DWCS 4	DWSR 4	DWS-T 33	DWSS 33	DHLW-3
...22	DWC 43			DWS-T 43	DWSS 43	

Insert page: 14

WTGNR/L

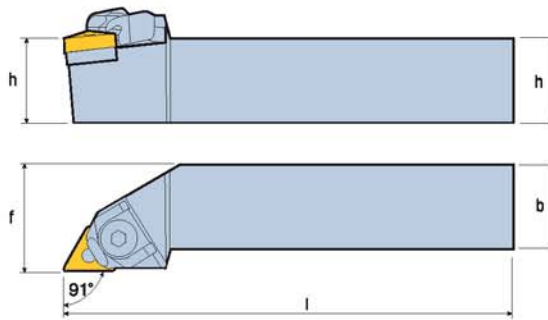
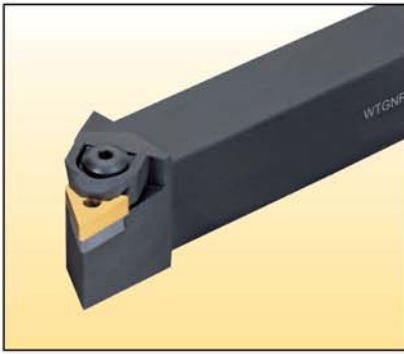

Designation	Dimension (mm)				Insert
	h	b	l	f	
WTGNR/L 2020 K16	20	20	125	25	TN□□ 1604 □□
2525 M16	25	25	150	32	

Holder/ Related insert	Component					
	Wedge Clamp	Screw	Snap Ring	Shim	Pin Screw	Wrench
...16	DWC 33	DWCS 4	DWSR 4	DWS-T 33	DWSS 33	DHLW-3

Insert page: 14

WTJNR/L

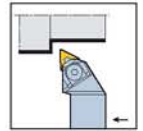
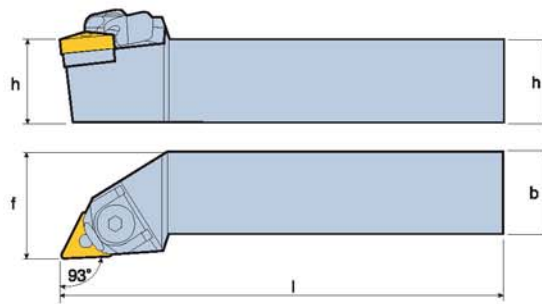

Designation	Dimension (mm)				Insert
	h	b	l	f	
WTJNR/L 2020 K16	20	20	125	25	TN□□ 1604 □□
2525 M16	25	25	150	32	

Holder/ Related insert	Component					
	Wedge Clamp	Screw	Snap Ring	Shim	Pin Screw	Wrench
...16	DWC 33	DWCS 4	DWSR 4	DWS-T 33	DWSS 33	DHLW-3

Insert page: 14

PWLNR/L

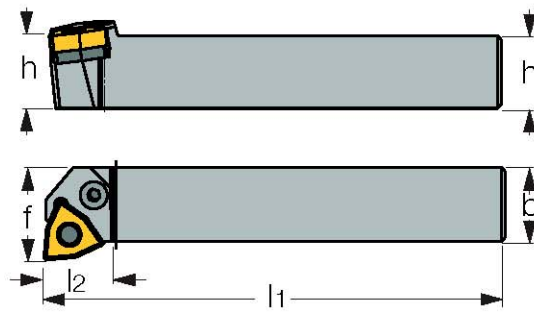

PWLNR-S

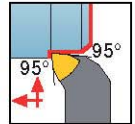
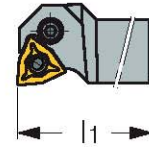

Designation	Dimension (mm)							Insert
	h	b	l ₁	l ₂	f	Ga°	Gr°	
2020 K08	20	20	125	21.6	25	-6	-6	WN.0804
WTGNR/L 2525 M08	25	25	150	18.0	32	-6	-6	
3232 P08	32	32	170	27.0	40	-6	-6	

Holder/ Related insert	Component					
	Seat	Spring Pin	Punch	Lever	Screw	Key
...08	DTWN 423	DSP 4	DPN 3-4	DLR 4	DS 117-2010	DHW 3.0

Insert page: 17

Designation System of Internal Boring Bar

1. Type of Boring

S: Steel Shank

A: Coolant Through Steel Shank

X: Special

2. Bar Diameter

3. Tool Length

K	125	U	350
M	150	V	400
Q	180	W	450
R	200	Y	500
S	250	X	Special
T	300		

4. Clamping System

P / Lever Lock

C / Top Clamp

S / Screw Clamp

M / Multi Lock

W / Wedge Clamp

S 25 T - P C L N R - 16 - □

1 2 3 4 5 6 7 8 9 10

5. Insert Shape

6. Approach Angle

7. Insert Clearance Angle

8. Hand of Tool

Right
Left Hand insert

Left
Right Hand insert

9. Cutting Edge Length

10. Manufacturer's Type

Unique to manufacturer

S-PCLNR/L

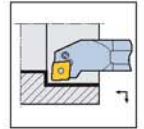
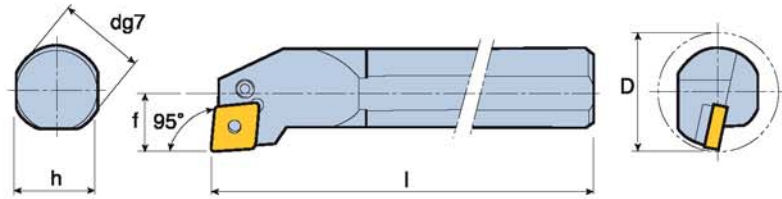

Designation	Dimension (mm)						Insert
	d	h	l	f	D		
S25T PCLNR/L 12	25	23	300	17	32	 CN□□ 1204 □□	
S32S PCLNR/L 12	32	30	250	22	40		
S32T PCLNR/L 12	32	30	300	22	40		
S40V PCLNR/L 12	40	37	400	27	50		
S50W PCLNR/L 12	50	47	450	35	63		
S40T PCLNR/L 12	40	37	300	27	50		
S50U PCLNR/L 12	50	47	350	35	63		

Holder/ Related Insert	Component					
	Lever	Screw	Shim	Shim Pin	Snap Ring	Wrench
S25T...12						
S32S...12	DLC 4B	DLCS 4B	-	-	DLSR 4B	DHLW-2.5
S32T...12	DLC 4	DLCS 4S	DLS-C 42	DSP 4	-	DHLW-3
S40V...12		DLCS 4				
S50W...12		DLCS 4				

Insert page: 11

S-PDUNR/L

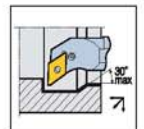
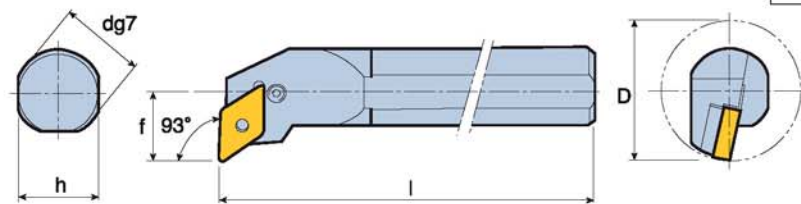

Designation	Dimension (mm)						Insert
	d	h	l	f	D		
S32T PDUNR/L 15	32	30	300	22	40	 DN□□ 1506 □□	
S40V PDUNR/L 15	40	37	400	27	50		
S50W PDUNR/L 15	50	47	450	35	63		

Holder/ Related Insert	Component				
	Lever	Screw	Shim	Shim Pin	Wrench
S32T...15					
S40V...15	DLC 4A	DLCS 4S	DLS-D 42	DSP 4	DHLW-3
S50W...15		DLCS 4			

Insert page: 12

S-PTFNR/L

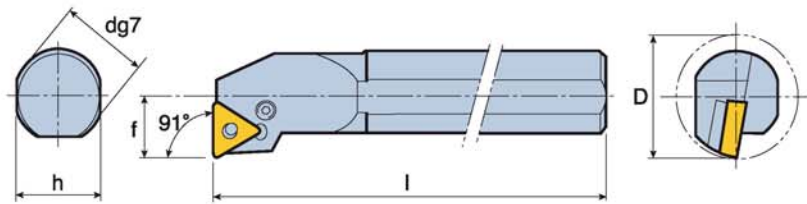
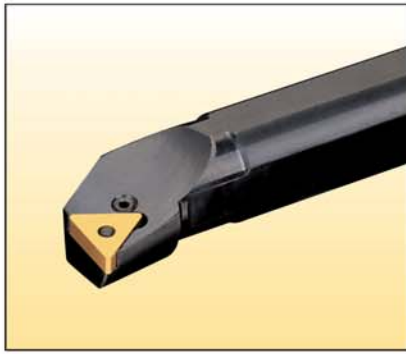

Designation	Dimension (mm)					Insert
	d	h	l	f	D	
S25T PTFNR/L 16	25	23	300	17	32	TN □ □ 1604 □ □
S32T PTFNR/L 16	32	30	300	22	40	

Holder/ Related Insert	Component					
	Lever	Screw	Shim	Shim Pin	Snap Ring	Wrench
S25T...16	DLC 3BH	DLCS 3B	-	-	DLSR 3B	DHLW-2
S32T...16	DLC 3	DLCS 3	DLS-T 31.8	DSP 3A	-	DHLW-2.5

Insert page: 14

S-SCLCR/L

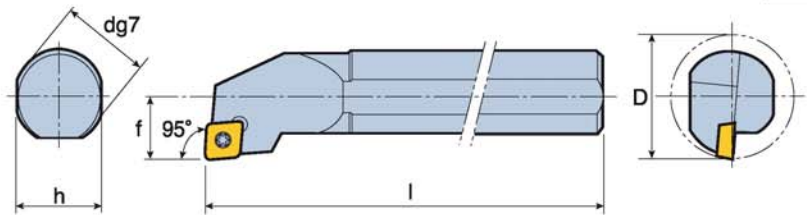

Designation	Dimension (mm)					Insert
	d	h	l	f	D	
S08K SCLCR/L 06	8	7	125	6	11	CC □ □ 0602 □ □ CC □ □ 09T3 □ □
S10K SCLCR/L 06	10	9	125	7	13	
S12M SCLCR/L 06	12	11	150	9	16	
S12M SCLCR/L 09	12	11	150	9	16	
S16M SCLCR/L 09	16	15	150	11	20	
S16R SCLCR/L 09	16	15	200	11	20	
S20R SCLCR/L 09	20	18	200	13	25	
S20S SCLCR/L 09	20	18	250	13	25	
S25T SCLCR/L 09	25	23	300	17	32	

Holder/ Related Insert	Component	
	Screw	Wrench
S80K,S10K...06	DS 25050I	DTFW-7
S12M...06	DS 25065I	
...09	DS 35080I	DTFW-15

Insert pages: 18, 20

S-SDQCR/L

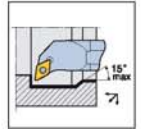
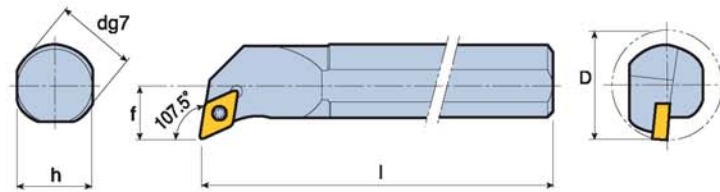

Designation	Dimension (mm)						Insert
	d	h	l	f	D		
S10K SDQCR/L 07	10	9	125	7	13	 DC□□ 0702 □□ DC□□ 11T3 □□	
S10M SDQCR/L 07	10	9	150	7	13		
S12M SDQCR/L 07	12	11	150	9	16		
S16R SDQCR/L 07	16	15	200	11	20		
S20S SDQCR/L 11	20	18	250	13	25		
S25T SDQCR/L 11	25	23	300	17	32		

Holder/ Related Insert	Component	
	Screw	Wrench
S10K,S10M...07	DS 25050I	 DTFW-7 DTFW-15
S12M,S16R...07	DS 25065I	
...11	DS 35080I	

Insert pages: 18, 20

S-SDUCR/L

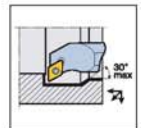
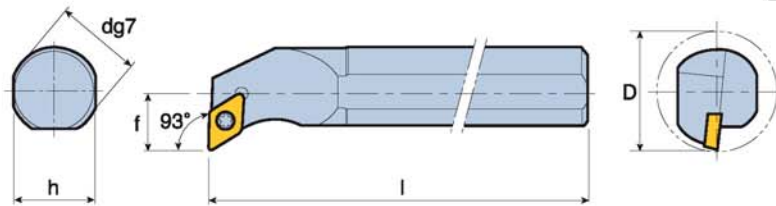

Designation	Dimension (mm)						Insert
	d	h	l	f	D		
S10K SDUCR/L 07	10	9	125	7	13	 DC□□ 0702 □□ DC□□ 11T3 □□	
S12M SDUCR/L 07	12	11	150	9	16		
S16M SDUCR/L 07	16	15	150	11	20		
S16R SDUCR/L 07	16	15	200	11	20		
S16R SDUCR/L 11	16	15	200	11	20		
S20S SDUCR/L 11	20	18	250	13	25		
S25T SDUCR/L 11	25	23	300	17	32		
S32U SDUCR/L 11	32	30	300	22	40		

Holder/ Related Insert	Component	
	Screw	Wrench
S10K...07	DS 25050I	 DTFW-7 DTFW-15
S12M...07	DS 25065I	
...11	DS 35080I	

Insert pages: 18, 20

S-SSKCR/L

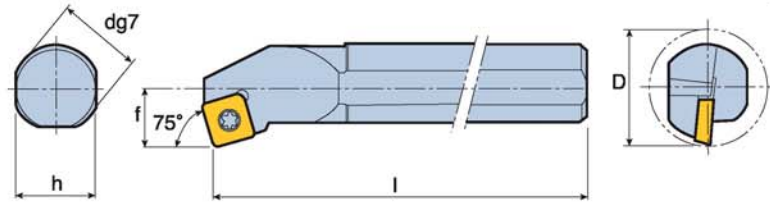

Designation	Dimension (mm)					Insert
	d	h	l	f	D	
S16R SSKCR/L 09	16	15	200	11	20	SC□□ 09T3 □□
S20S SSKCR/L 09	20	18	250	13	25	

Holder/ Related Insert	Component	
	Screw	Wrench
...09	 DS 35080I	 DTFW-15

Insert pages: 19, 20

S-STFCR/L

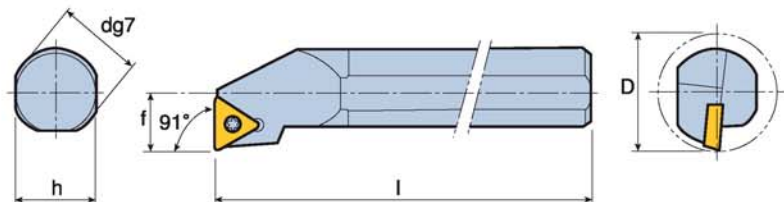

Designation	Dimension (mm)					Insert
	d	h	l	f	D	
S08K STFCR/L 09	8	7	125	6	11	TC□□ 0902 □□ <hr/> TC□□ 1102 □□ <hr/> TC□□ 16T3 □□
S10K STFCR/L 09	10	9	125	7	13	
S12M STFCR/L 09	12	11	150	9	16	
S12M STFCR/L 11	12	11	150	9	16	
S16R STFCR/L 11	16	15	200	11	20	
S20S STFCR/L 11	20	18	250	13	25	
S20S STFCR/L 16	20	18	250	13	25	
S25T STFCR/L 16	25	23	300	17	32	

Holder/ Related Insert	Component			
	Screw	Shim	Shim Screw	Wrench
S08K...09	DS 22046I-TS	-	-	DTFW-7
S10K...09	DS 22050I			
...11	DS 25065I			
S20S...16	DS 35080I	DSS-T 32	-	DTFW-15
S25T...16	DS 35124I			

Insert pages: 19, 21

S-SVUBR/L

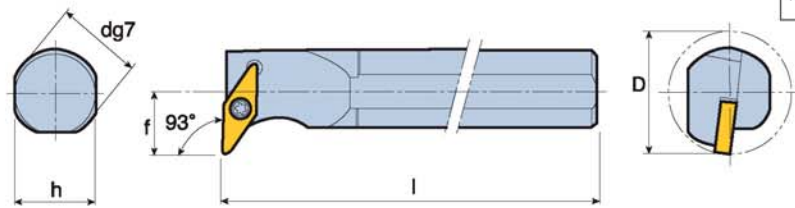
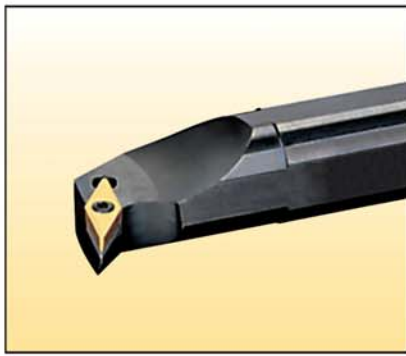

Designation	Dimension (mm)					Insert
	d	h	l	f	D	
S32T SVUBR/L 16	32	30	300	22	40	VB□□ 1604 □□
S40V SVUBR/L 16	40	37	400	27	50	

Holder/ Related Insert	Component			
	Screw	Shim	Shim Screw	Wrench
...11	DS 35124I	DSS-V 32	DSC 50090S	DTFW-15

Insert page: 16

S-WTFNR/L

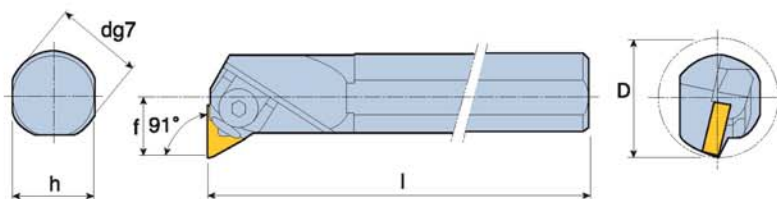

Designation	Dimension (mm)					Insert
	d	h	l	f	D	
S25T WTFNR/L 16	25	23	300	17	32	TN□□ 1604 □□
S32U WTFNR/L 16	32	30	350	22	40	

Holder/ Related Insert	Component					
	Wedge Clamp	Screw	Snap Ring	Shim	Pin Screw	Wrench
S25T...16	DWC 33	DWCS 4B	DWSR 4	-	DWSS 33-1	DHLW-3
S32U...16				DWS-T 33	DWSS 33	

Insert page: 14

A/S-PWLNRL/L

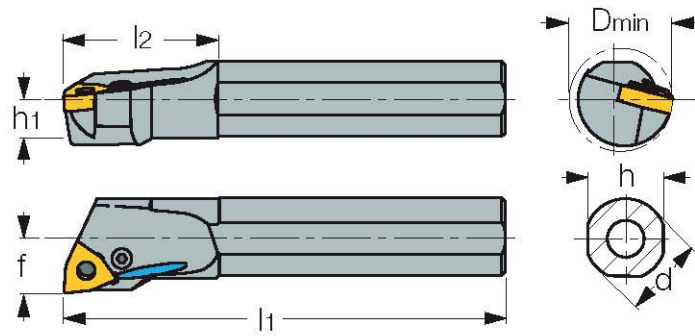

Designation	Dimension (mm)									
	d	l ₁	l ₂	h	h ₁	f	D _{min}	°G _a	°G _r	Coolant
S25S PWLNRL-08	25.00	250.00	47.0	23.0	11.5	17.0	32.00	-5	-12.5	N
S32T PWLNRL-08	32.00	300.00	50.0	29.0	14.5	22.0	39.00	-6	-12	N
S40U PWLNRL-08	40.00	350.00	59.0	36.0	18.0	27.0	49.00	-6	10	N

Holder/ Related insert	Component					
	Seat	Spring Pin	Punch	Lever	Screw	Key
...08	DTWN 423	DSP 4	DPN 3-4	DLR 4	DS 117-2010	DHW 3.0

Insert page: 17

CNGN-Ceramic

80° Rhombic Double-Sided Ceramic Inserts with a T-Land for Machining Cast Iron, Hardened Steel and Nickel Based Alloys

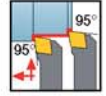
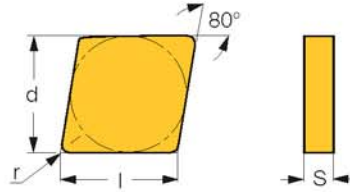

Designation	Dimensions				Tough ↔ Hard							Recommended Machining Data	
	l	di	S	r	DW7	DC9	DC8	DC80	DC23	DC22	DC420	ap (mm)	f (mm/rev)
CNGN 120404T	12.90	12.70	4.76	0.40	●				●			1.00-3.00	0.10-0.43
CNGN 120408E	12.90	12.70	4.76	0.80		●						1.00-3.00	0.10-0.50
CNGN 120408T	12.90	12.70	4.76	0.80	●		●	●	●	●	●	1.00-3.00	0.10-0.50
CNGN 120408T0225-WG ⁽¹⁾	12.90	12.70	4.76	0.80	●							1.00-3.00	0.10-0.50
CNGN 120412E	12.90	12.70	4.76	1.20		●						1.00-5.00	0.10-0.50
CNGN 120412T	12.90	12.70	4.76	1.20	●		●	●	●			1.00-4.00	0.10-0.50
CNGN 120416T	12.90	12.70	4.76	1.60	●		●	●				1.00-5.00	0.10-0.50
CNGN 120708E	12.90	12.70	7.94	0.80		●						1.00-4.00	0.10-0.50
CNGN 120708T	12.90	12.70	7.94	0.80	●				●			1.00-4.00	0.10-0.50
CNGN 120712E	12.90	12.70	7.94	1.20		●						1.00-5.00	0.10-0.50
CNGN 120712T	12.90	12.70	7.94	1.20	●		●	●				1.00-4.00	0.10-0.50
CNGN 120716T	12.90	12.70	7.94	1.60	●		●	●				1.00-5.00	0.10-0.50
CNGN 160612T	16.10	15.88	6.35	1.20			●					1.00-5.00	0.10-0.50

⁽¹⁾ Wiper edge configuration for finishing operations at high feeds

CNGN-Ceramic

80° Rhombic Double-Sided Ceramic Inserts with a T-Land for Machining Cast Iron, Hardened Steel and Nickel Based Alloys

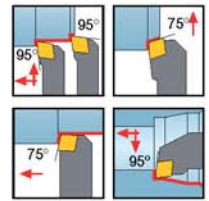
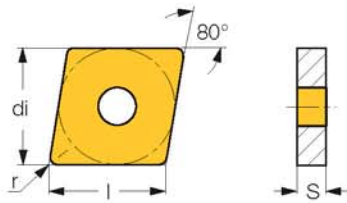

Designation	Dimensions				Tough ↔ Hard								Recommended Machining Data	
	l	di	S	r	DC9	DC8	DC80	DC6	DC23	DC22	DC420	DC11	ap (mm)	f (mm/rev)
CNGA 120404T	12.90	12.70	4.76	0.40					●	●	●		0.07-0.40	0.05-0.20
CNGA 120408E	12.90	12.70	4.76	0.80	●								0.07-0.40	0.05-0.20
CNGA 120408T	12.90	12.70	4.76	0.80		●	●	●	●	●	●	●	0.07-0.40	0.05-0.20
CNGA 120412T	12.90	12.70	4.76	1.20		●		●	●	●	●		0.07-0.50	0.05-0.20
CNGA 120416T	12.90	12.70	4.76	1.60		●	●		●				0.07-0.50	0.05-0.20

SNGN-Ceramic

Square Double-Sided Ceramic Inserts with Flat Rake for Cast Iron, Hardened Steel and Super Alloys

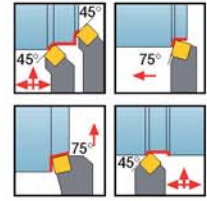
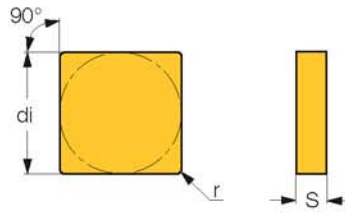
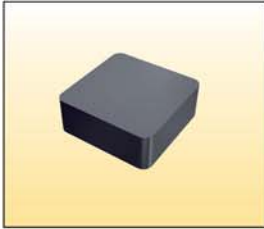

Designation	Dimensions			Tough ↔ Hard								Recommended Machining Data		
	di	S	r	DW7	DC9	DC8	DC80	DC6	DC23	DC22	DC420	DC11	a _p (mm)	f (mm/rev)
SNGN 090308T	9.52	4.76	0.80	●									0.10-3.00	0.10-0.50
SNGN 090412T	9.52	4.76	1.20			●							0.10-3.00	0.10-0.50
SNGN 120404T	12.70	4.76	0.40							●			0.10-3.50	0.10-0.50
SNGN 120408T	12.70	4.76	0.80	●		●	●		●	●	●		0.10-3.50	0.10-0.50
SNGN 120412T	12.70	4.76	1.20	●		●	●	●	●	●	●	●	0.10-5.00	0.10-0.50
SNGN 120416E	12.70	4.76	1.60		●								0.10-5.00	0.10-0.50
SNGN 120416T	12.70	4.76	1.60	●		●	●			●	●		0.10-5.00	0.10-0.50
SNGN 120420T	12.70	4.76	2.00			●							0.10-5.00	0.10-0.50
SNGN 120708T	12.70	4.76	0.80	●					●	●	●		0.10-5.00	0.10-0.50
SNGN 120712T	12.70	7.94	1.20	●		●	●		●			●	0.10-5.00	0.10-0.50
SNGN 120716T	12.70	7.94	1.60	●		●	●		●	●		●	0.10-5.00	0.10-0.50
SNGN 150712T	15.87	6.35	1.20	●									0.10-5.00	0.10-0.50
SNGN 150716T	15.87	6.35	1.60	●		●							0.10-5.00	0.10-0.50

SNGA-Ceramic

Square Double-Sided Ceramic Inserts with Flat Rake for Cast Iron and Hardened Steel

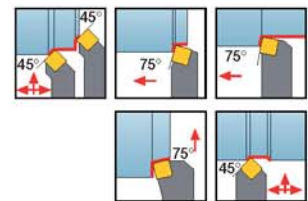
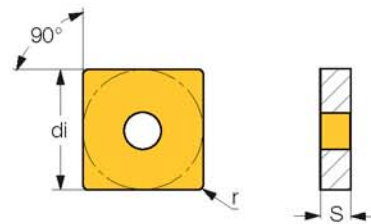

Designation	Dimensions			Tough ↔ Hard				Recommended Machining Data	
	di	S	r	DC8	DC23	DC22	DC420	a _p (mm)	f (mm/rev)
SNGA 120404T	12.70	4.76	0.40			●		0.10-3.00	0.05-0.30
SNGA 120408T	12.70	4.76	0.80	●	●	●	●	0.10-3.50	0.05-0.30
SNGA 120412T	12.70	4.76	1.20	●	●			0.10-4.00	0.05-0.30
SNGA 120416T	12.70	4.76	1.60	●				0.10-4.50	0.05-0.30

DNGA-Ceramic

55° Rhombic Double-Sided Ceramic Inserts for Machining Cast Iron and Hardened Steel

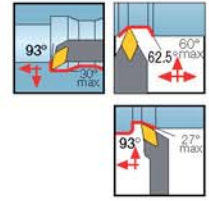
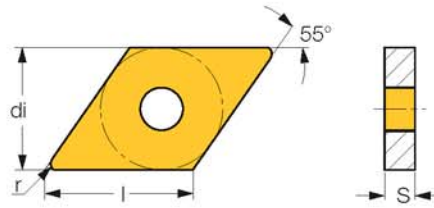
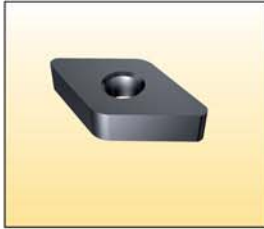

Designation	Dimensions				Tough ↔ Hard				Recommended Machining Data	
	l	di	S	r	DC8	DC23	DC22	DC420	a_p (mm)	f (mm/rev)
DNGA 150404T	15.50	12.70	4.76	0.40		●			0.10-3.00	0.07-0.50
DNGA 150408T	15.50	12.70	4.76	0.80	●	●	●	●	0.10-3.50	0.07-0.50
DNGA 150412T	15.50	12.70	4.76	1.20		●			0.10-4.00	0.07-0.50
DNGA 150604T	15.50	12.70	6.35	0.40		●			0.10-3.50	0.07-0.50
DNGA 150608T	15.50	12.70	6.35	0.80		●		●	0.10-4.00	0.07-0.50
DNGA 150612T	15.50	12.70	6.35	1.20			●	●	0.10-5.00	0.07-0.50

TNGA-Ceramic

Triangular Double-Sided Ceramic Inserts for Machining Super Alloys and Hardened Steel

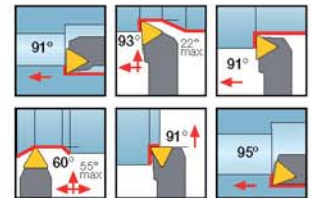
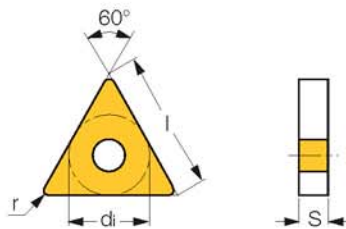

Designation	Dimensions				Tough ↔ Hard				Recommended Machining Data	
	l	di	S	r	DC9	DC23	DC22	DC420	a_p (mm)	f (mm/rev)
TNGA 160404T	16.50	9.52	4.76	0.40		●	●	●	0.10-3.00	0.07-0.50
TNGA 160408E	16.50	9.52	4.76	0.80	●				0.10-3.50	0.07-0.50
TNGA 160408T	16.50	9.52	4.76	0.80		●	●	●	0.10-3.50	0.07-0.50
TNGA 160412T	16.50	9.52	4.76	1.20		●			0.10-4.00	0.07-0.50

TPGN-Ceramic

Triangular 11° Positive Flank Ceramic Inserts for Machining Hardened Steel

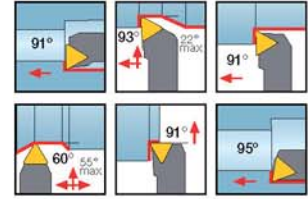
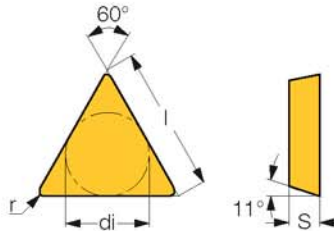

Designation	Dimensions				Tough ↔ Hard			Recommended Machining Data	
	l	di	S	r	DC23	DC22	DC420	a_p (mm)	f (mm/rev)
TPGN 090204T	9.60	5.56	2.38	0.40		●		0.10-1.50	0.07-0.30
TPGN 110304T	11.00	6.35	3.17	0.40	●	●	●	0.10-1.50	0.07-0.30
TPGN 110308T	11.00	6.35	3.17	0.80	●	●	●	0.10-3.00	0.07-0.40
TPGN 160304T	16.50	9.52	3.17	0.40	●	●	●	0.10-4.00	0.07-0.50
TPGN 160308T	16.50	9.52	3.17	0.80	●	●	●	0.10-4.00	0.07-0.50
TPGN 220408T	22.00	12.70	4.76	0.80	●			0.10-5.00	0.07-0.50

RNGN-Ceramic

Round Double-Sided Ceramic Inserts for Machining Cast Iron, Nickel Based Alloys and Hardened Steel

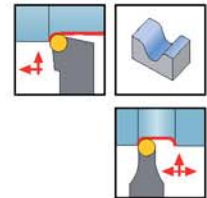
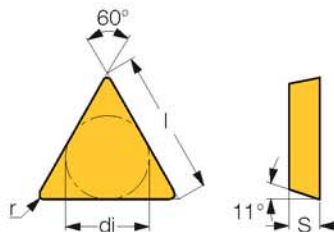
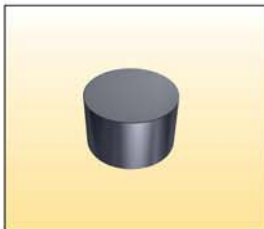

Designation	Dimensions		Tough ↔ Hard							Recommended Machining Data		
	di	S	DC7	DC9	DC8	DC80	DC23	DC22	DC420	DC11	a_p (mm)	f (mm/rev)
RNGN 090300T	9.53	3.18	●								0.10-2.00	0.07-0.20
RNGN 090400T	9.53	4.76	●								0.10-2.00	0.07-0.20
RNGN 120400E	12.70	4.76	●	●							0.10-3.50	0.07-0.50
RNGN 120400T	12.70	4.76	●		●	●		●	●		0.10-3.50	0.07-0.50
RNGN 120700 S6 (1)	12.70	7.94	●								1.00-2.00	-
RNGN 120700E	12.70	7.94	●								0.10-2.00	0.07-0.20
RNGN 120700E01 (1)	12.70	7.94	●								1.00-2.00	-
RNGN 120700T	12.70	7.94	●	●			●	●	●		0.10-4.50	0.07-0.50
RNGN 120700T01020	12.70	7.94		●							0.10-4.50	0.07-0.50
RNGN 120700T0220	12.70	7.94	●								0.10-2.00	0.07-0.20
RNGN 150700T	15.76	7.94	●								0.10-3.00	0.07-0.20
RNGN 190700T	19.05	7.94	●								0.10-3.00	0.07-0.20
RNGN 250700T	25.00	7.94							●		0.10-5.00	0.07-0.50

CTJNR/L

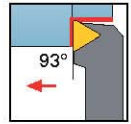
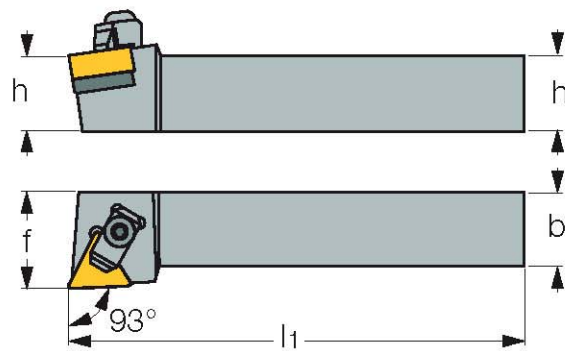

Designation	Dimension (mm)						Inserts
	h	b	l ₁	f	°G _a	°G _r	
CTJNR/L 2020K-16CEA	20.0	20.0	125.00	25.0	-4	-4	TNGN 1604
CTJNR/L 2525M-16CEA	25.0	25.0	150.00	32.0	-4	-4	

Spare Parts



Designation	Seat	Key	Clamp	Clamp Screw	Seat Screw
CTJNR/L	DSS-T3	DHLW4.0	DBCL 6 CLAMP	DS M6X1X25ISO7380	SR M5X0.8X10

CCLNR/L External Toolholders for Ceramic Inserts

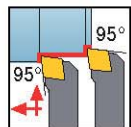
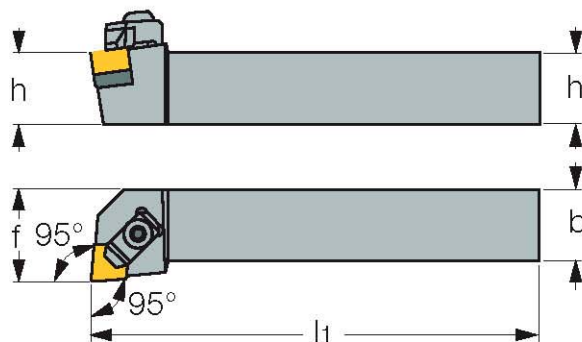

Designation	Dimension (mm)						Inserts
	h	b	l ₁	f	°G _a	°G _r	
CCLNR/L 2020K-12CE	20.0	20.0	125.00	25.0	-4	-6	CNGN 1207
CCLNR/L 2020K-12CEA	20.0	20.0	125.00	25.0	-4	-6	CNGN 1204
CCLNR/L 2525M-12CE	25.0	25.0	150.00	32.0	-4	-6	CNGN 1207
CCLNR/L 2525M-12CEA	25.0	25.0	150.00	32.0	-4	-6	CNGN 1204

Spare Parts



Designation	Seat	Key	Clamp	Clamp Screw	Seat Screw
CCLNR/L	DSS-S48	DHLW4.0	DBCL 6 CLAMP	DS M6X1X25ISO7380	SR M5X0.8X10

CSKNR/L

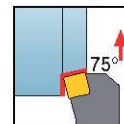
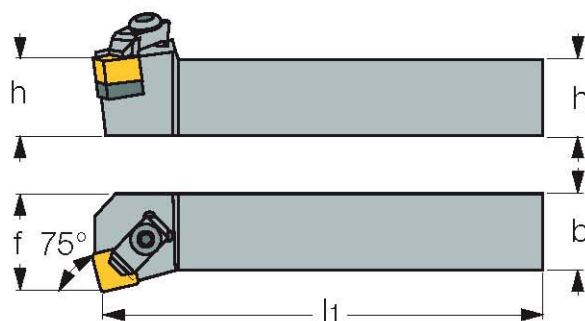

Designation	Dimension (mm)						Inserts
	h	b	l_1	f	$^\circ G_a$	$^\circ G_r$	
CSKNR/L 2525M-12CE	25.0	25.0	150.00	32.0	-4	-4	SNGN 1207
CSKNR 2525M-12CEA	25.0	25.0	150.00	32.0	-4	-4	SNGN 1204
CSKNR 3225P-12CE	32.0	25.0	170.00	32.0	-4	-4	SNGN 1207

CSRNR/L

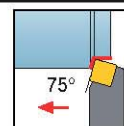
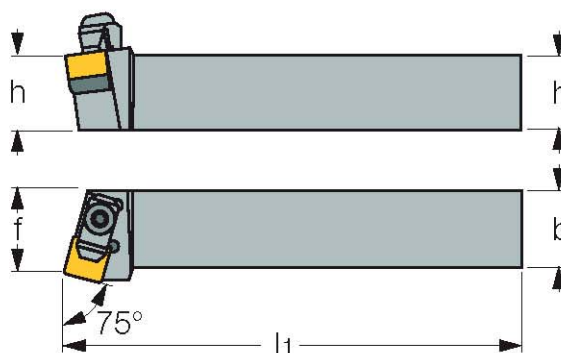

Designation	Dimension (mm)						Inserts
	h	b	l_1	f	$^\circ G_a$	$^\circ G_r$	
CSRNR 2020K-12CE	20.0	20.0	125.00	22.0	-5.2	-4.5	SNGN 1207
CSRNR/L 2525M-12CE	25.0	25.0	150.00	27.0	-5.2	-4.5	SNGN 1207
CSRNR/L 2525M-12CEA	25.0	25.0	150.00	27.0	-5.2	-4.5	SNGN 1204
CSRNR/L 3225P-12CE	32.0	25.0	170.00	27.0	-5.2	-4.5	SNGN 1207

CRDNN

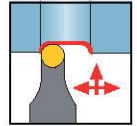
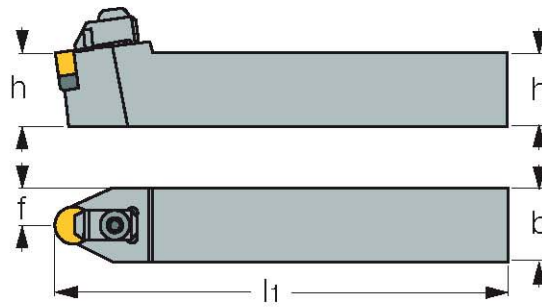

Designation	Dimension (mm)						Inserts
	h	b	l_1	f	$^\circ G_a$	$^\circ G_r$	
CRDNN 2020K-12CE	20.0	20.0	125.00	10.0	-8.5	0	RNGN 120700
CRDNN 2020K-12CEA	20.0	20.0	125.00	10.0	-8.5	0	RNGN 120400
CRDNN 2525M-12CE	25.0	25.0	150.00	12.5	-8.5	0	RNGN 120700
CRDNN 2525M-12CEA	25.0	25.0	150.00	12.5	-8.5	0	RNGN 120400
CRDNN 3225P-12CE	32.0	25.0	170.00	12.5	-8.5	0	RNGN 120700

CRGNR/L

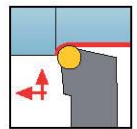
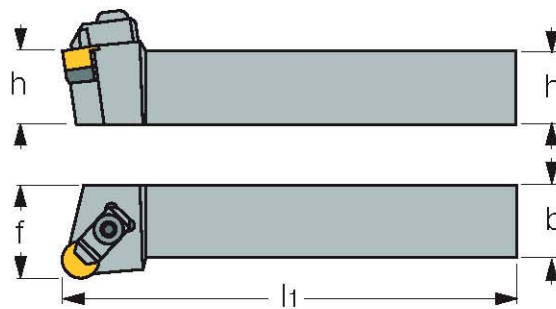

Designation	Dimension (mm)						Inserts
	h	b	l_1	f	$^\circ G_a$	$^\circ G_r$	
CRGNL 2020K-12CE	20.0	20.0	125.00	25.0	-6	-6	RNGN 120700
CRGNR/L 2020K-12CEA	20.0	20.0	125.00	25.0	-6	-6	RNGN 120400
CRGNR/L 2525M-12CE	25.0	25.0	150.00	32.0	-6	-6	RNGN 120700
CRGNR/L 2525M-12CEA	25.0	25.0	150.00	32.0	-6	-6	RNGN 120400
CRGNR/L 3225P-12CE	32.0	25.0	170.00	32.0	-6	-6	RNGN 120700

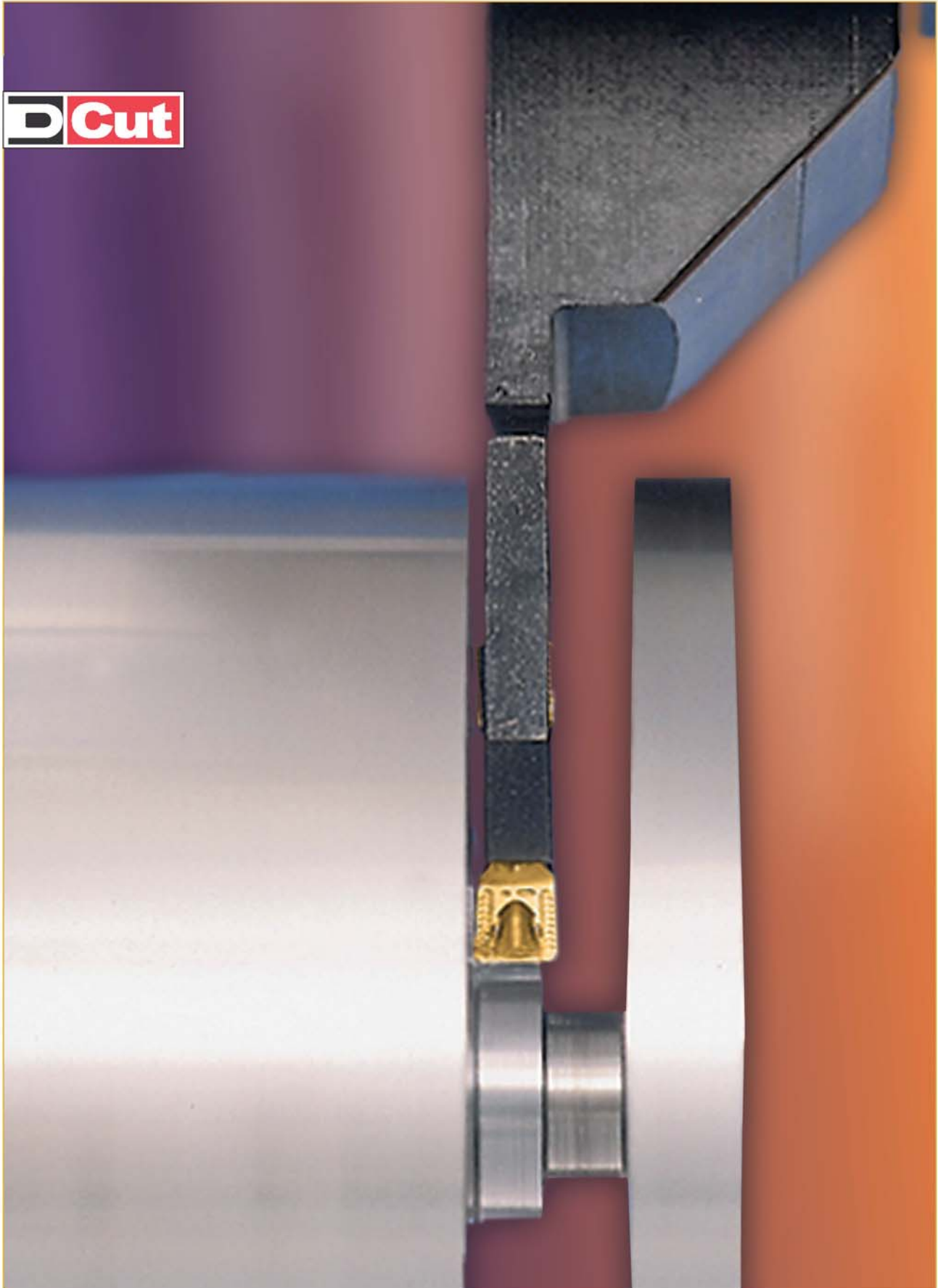

DCut

Cut System Presentation	56
Cut Designation	57-58
Inserts	59-63
Blades - Cut-off and deep grooving	64
Toolholders - Cut-off and grooving - Turning and grooving - Undercutting and recessing	65-66
Boring Bars - ID turning and grooving	67
Tool Blocks	68
Technical Data	69-74

System Presentation

The D Cut System

The D Cut system covers a wide range of operations. The system is unique for its flexibility and economy. It offers three types of inserts and a wide versatile range of tools.

The available operations with the D Cut system are:

- Grooving and cut-off
- Precision grooving and recessing
- Turning
- Undercutting and recessing

D Cut inserts are provided with three different types of chipbreakers. Each is designed for optimum performance in a specific application field. Select the geometry most suited for your applications.



C-Type

DIMC inserts are ideal for cut-off and grooving on most types of steel, alloy steel and stainless steel. It has a strong cutting edge, which makes it the first choice for hard materials and tough applications at medium-to-high feeds.



J-Type

DIMJ inserts are ideal for cut-off and grooving for general applications in low-to-medium feeds on carbon steel, alloy steel and austenitic stainless steel. The cutting edge has a positive rake, which makes it the first choice for soft materials, small diameters, and thin-walled parts.

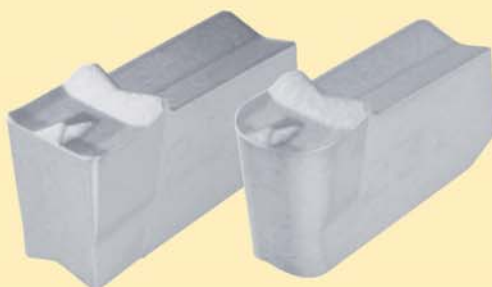

V-Type

DIPV are made for precision grooving, recessing, turning and profiling. (± 0.02 mm width tolerance). The DIPV are equipped with various corner radii. The V-type is a multi-directional chipformer.

Cut-off Grooving and Profiling Inserts ISO Designation System

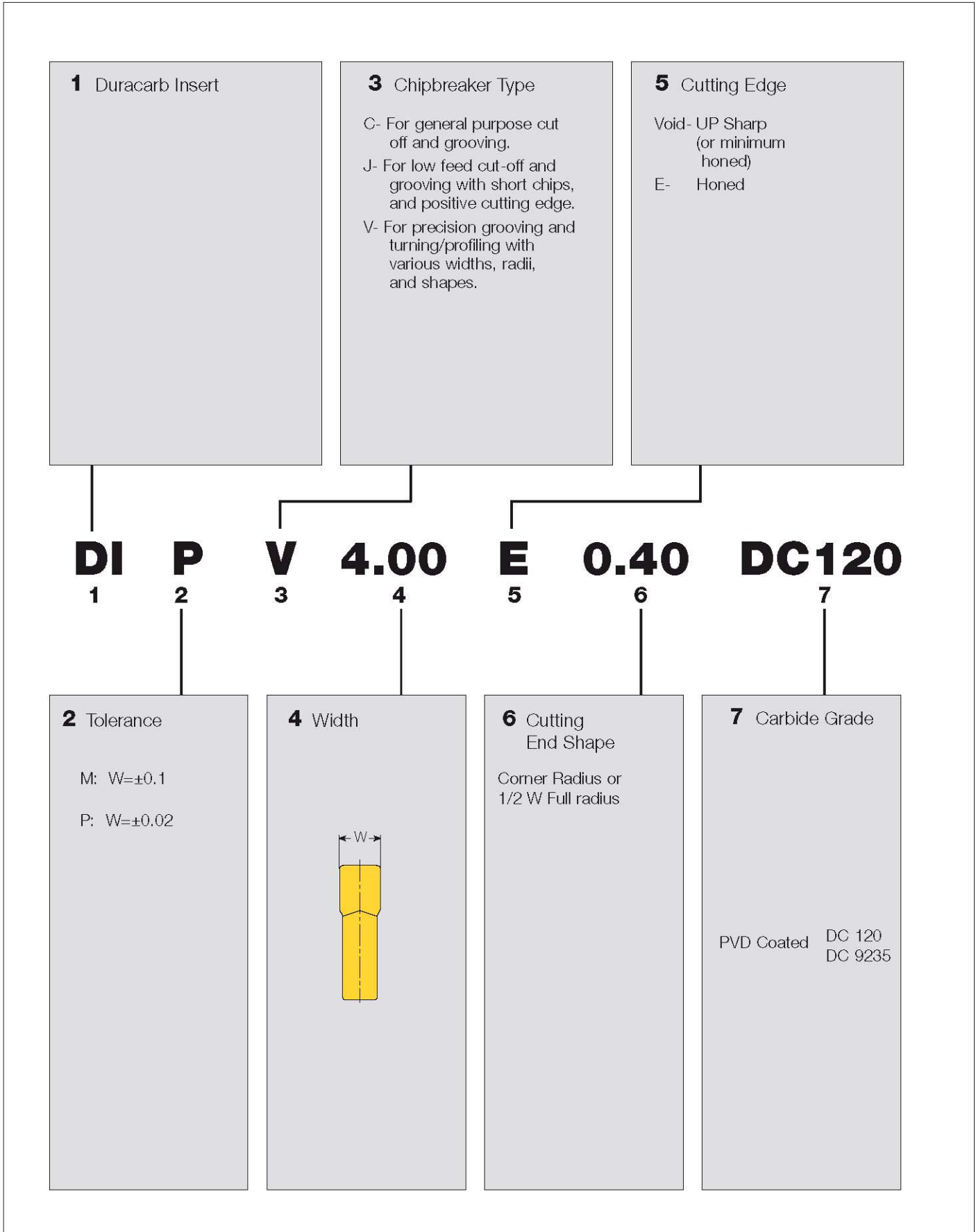

Toolholders, Grooving Bars and Blades ISO Designation System

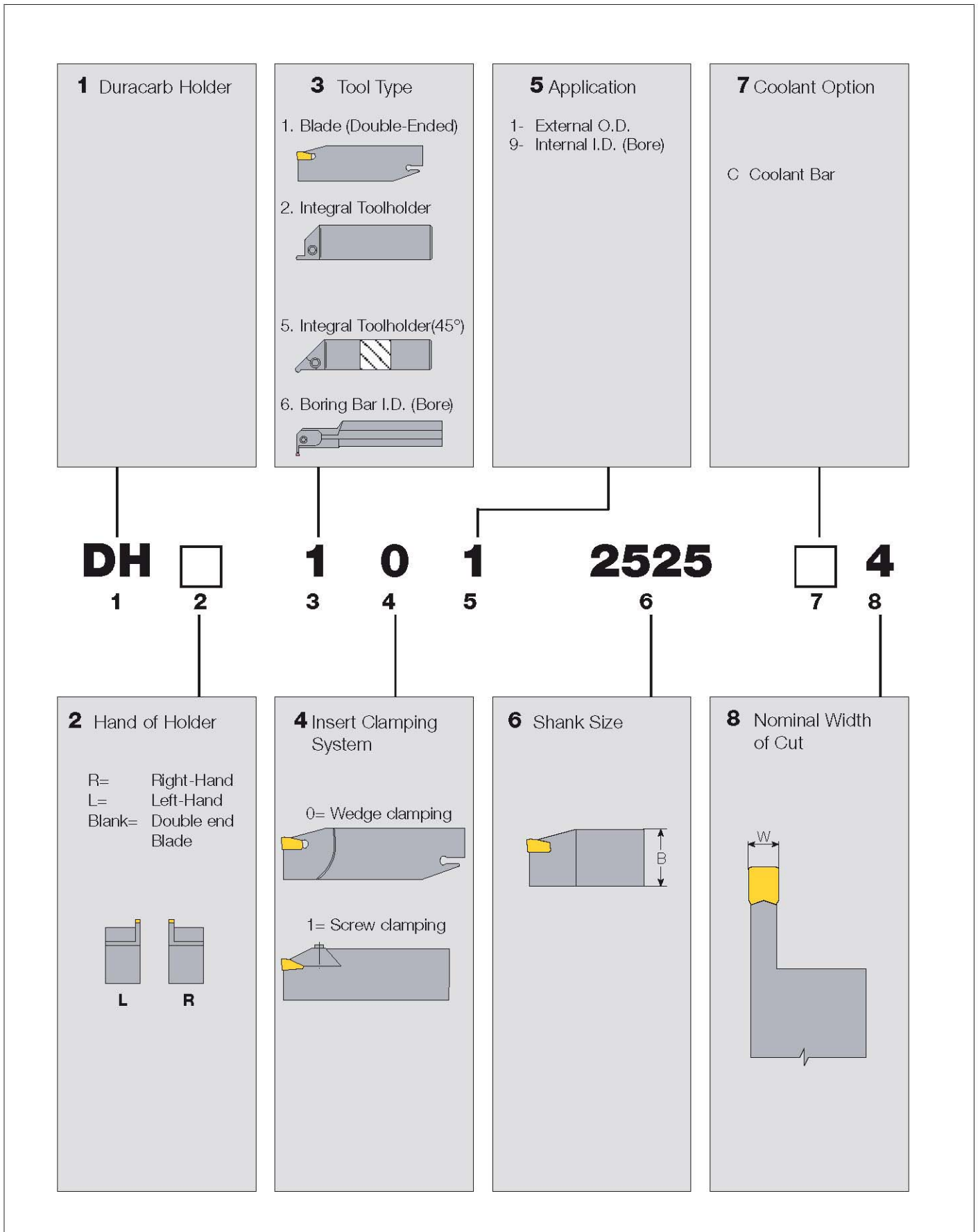

Inserts Parting and Deep Grooving

DIMC

With C-type Chipbreakers

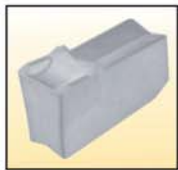
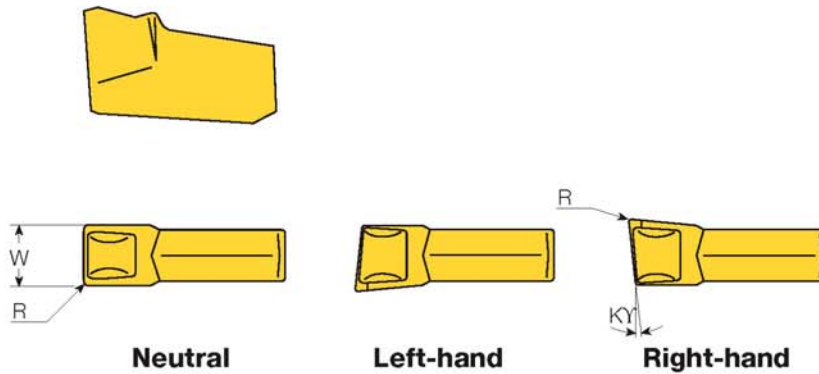

DIMC

Designation	W	K (degrees)	R	Grades	
				DC120	DC9235
				Coated	
DIMC 2	2.2	0°	0.20	•	•
DIMC 2 6L	2.2	6°	0.20	•	•
DIMC 2 6R	2.2	6°	0.20	•	•
DIMC 2.4	2.4	0°	0.20	•	•
DIMC 2.4 6L	2.4	6°	0.20	•	•
DIMC 2.4 6R	2.4	6°	0.20	•	•
DIMC 3	3.1	0°	0.20	•	•
DIMC 3 6L	3.1	6°	0.20	•	•
DIMC 3 6R	3.1	6°	0.20	•	•

Width tolerance ± 0.1 mm

Inserts Parting and Deep Grooving

DIMC

With C-type Chipbreakers

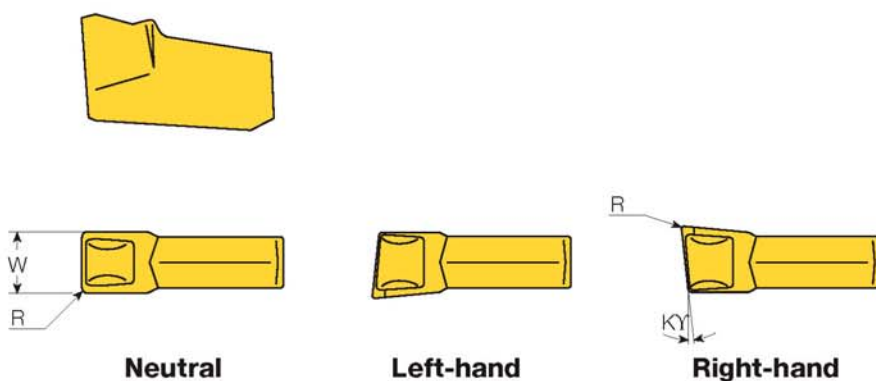

DIMC

Designation	W	K (degrees)	R	Grades	
				DC120	DC9235
				Coated	
DIMC 4	4.1	0°	0.25	•	•
DIMC 4 6L	4.1	6°	0.25	•	•
DIMC 4 6R	4.1	6°	0.25	•	•
DIMC 4.8	4.8	0°	0.28	•	•
DIMC 4.8 6L	4.8	6°	0.28	•	•
DIMC 4.8 6R	4.8	6°	0.28	•	•

Width tolerance ± 0.1 mm

Inserts Parting and Deep Grooving

DIMJ

With J-type Chipbreakers

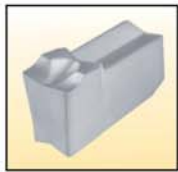
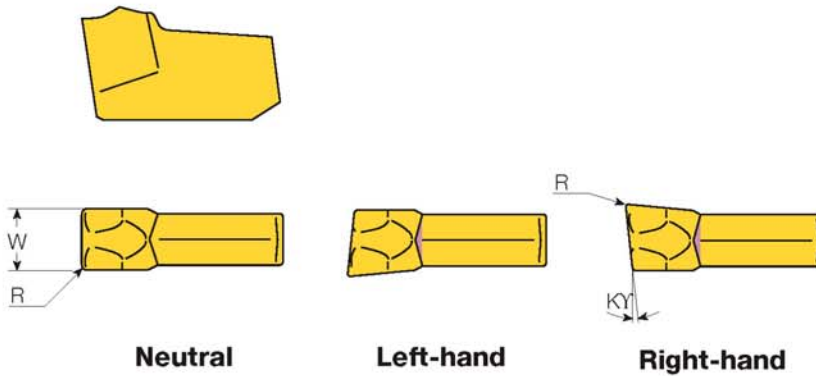

DIMJ

Designation	W	K (degrees)	R	Grades	
				DC120	DC9235
DIMJ 2	2.2	0°	0.20	•	•
DIMJ 2 6L	2.2	6°	0.20	•	•
DIMJ 2 6R	2.2	6°	0.20	•	•
DIMJ 2.4	2.4	0°	0.20	•	•
DIMJ 2.4 6L	2.4	6°	0.20	•	•
DIMJ 2.4 6R	2.4	6°	0.20	•	•
DIMJ 3	3.1	0°	0.20	•	•
DIMJ 3 6L	3.1	6°	0.20	•	•
DIMJ 3 6R	3.1	6°	0.20	•	•
DIMJ 4	4.1	0°	0.25	•	•
DIMJ 4 6L	4.1	6°	0.25	•	•
DIMJ 4 6R	4.1	6°	0.25	•	•

Width tolerance ± 0.1 mm

Inserts Precision Grooving and Turning (E-type)

DIPV

With V-type Chipbreakers

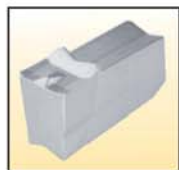
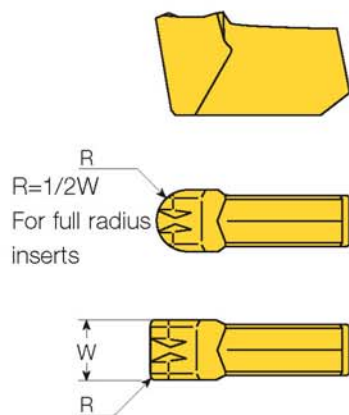

DIPV...E

Designation	W	R	Grades
			Coated DC9235
DIPV 3.00E 0.40	3.00	0.40	•
DIPV 4.00E 0.40	4.00	0.40	•
DIPV 5.00E 0.40	5.00	0.40	•
DIPV 3.00E 1.50	3.00	1.50	•
DIPV 4.00E 2.00	4.00	2.00	•

Width tolerance ± 0.02 mm

* The E type inserts are honed.

Inserts Precision Grooving

DIPV

With V-type Chipbreakers

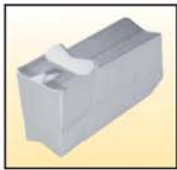
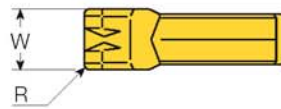

DIPV

Designation	W	R	Grades	
			Coated	
			DC120	DC9235
DIPV 1.85 0.10	1.85	0.10	•	•
DIPV 2.00 0.20	2.00	0.20	•	•
DIPV 2.15 0.15	2.15	0.15	•	•
DIPV 2.65 0.15	2.65	0.15	•	•
DIPV 3.00 0.20	3.00	0.20	•	•
DIPV 3.18 0.20	3.18	0.20	•	•
DIPV 4.00 0.20	4.00	0.20	•	•
DIPV 4.15 0.15	4.15	0.15	•	•

Width tolerance ± 0.02 mm

Blades Cut-off and Deep Grooving

DH 101

Use insert type: DIMC, DIMJ, DIPV

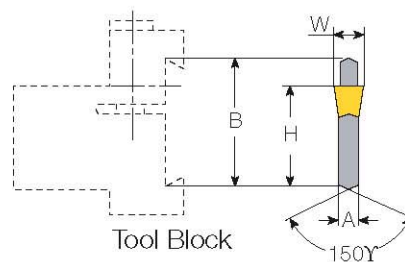
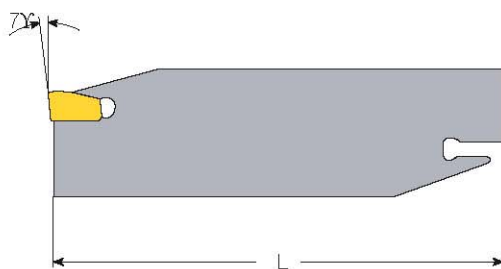
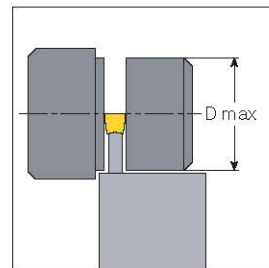

Designation	B	W Insert	A	L	H	D max
DH 101 26 2		1.85-2.5	1.6 [Ⓜ]		21.4	50
DH 101 26 3	26	2.7-3.9	2.4	110	21.4	75
DH 101 26 4		3.7-4.7	3.2		21.4	80
DH 101 32 2		1.85-2.5	1.6 [Ⓜ]		24.8	50
DH 101 32 3	32	2.7-3.9	2.4	150	24.8	100
DH 101 32 4		3.7-4.7	3.2		24.8	100

Note: Blades should not be used for turning or profiling.

Blades supplied with insert extractor. Inserts must be ordered separately.

[Ⓜ] A=1.2 at DOC area only. Overall thickness is 1.6mm.

[Ⓜ] A=1.6 at DOC area only. Overall thickness is 2.4mm.

Toolholders Cut-off and Grooving

DHR/L 201

Use insert type: DIMC, DIMJ, DIPV

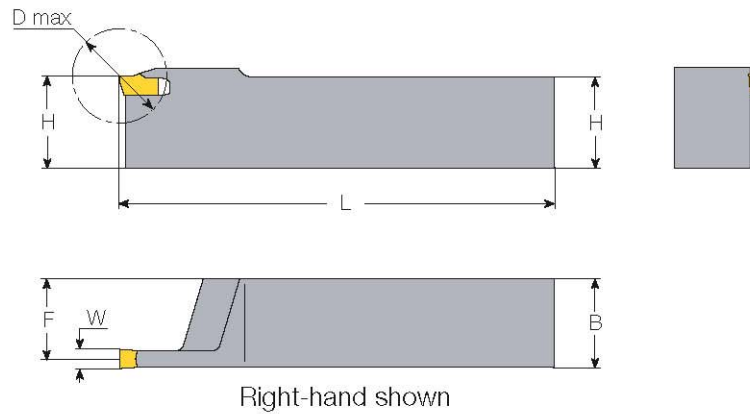
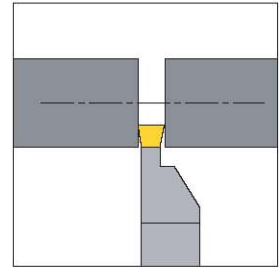

Designation	H	W Insert	Dmax	B	L	F
DHR/L 201 1212 2	12	1.85-2.5	32	12	110	11.2
DHR/L 201 1212 3	12	2.7-3.9	32	12	110	10.8
DHR/L 201 1616 2	16	1.85-2.5	32	16	110	15.2
DHR/L 201 1616 3	16	2.7-3.9	35	16	110	14.8
DHR/L 201 2020 2	20	1.85-2.5	35	20	110	19.2
DHR/L 201 2020 3	20	2.7-3.9	52	20	120	18.8
DHR/L 201 2020 4	20	3.7-4.7	57	20	120	18.4
DHR/L 201 2525 3	25	2.7-3.9	56	25	150	23.8
DHR/L 201 2525 4	25	3.7-4.7	65	25	150	23.4

Toolholder supplied with insert extractor. Inserts must be ordered separately.

Note: These toolholders should not be used for turning operations.

Select DHR/L 211 toolholders for turning.

Toolholders Turning and Grooving

DHR/L 211

Use insert type: DIMC, DIMJ, DIPV

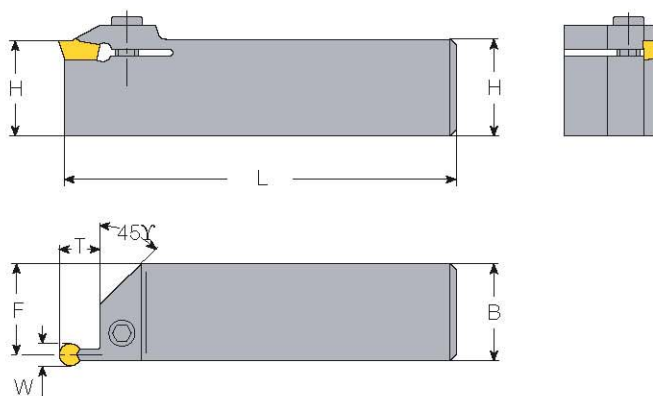
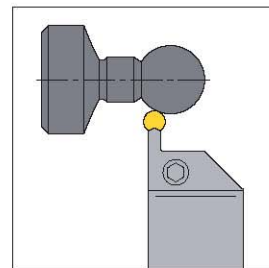

Right-hand shown

Designation	W Range	F	H	B	L	T
DHR/L 211 1616 3	2.8-3.6	14.7	16	16	100	9.9
DHR/L 211 1616 4	3.6-4.6	14.2	16	16	100	13.0
DHR/L 211 2020 3	2.8-3.6	18.7	20	20	125	9.9
DHR/L 211 2020 4	3.6-4.6	18.2	20	20	125	13.0
DHR/L 211 2525 3	2.8-3.6	23.7	25	25	150	9.9
DHR/L 211 2525 4	3.6-4.6	23.2	25	25	150	13.0

DIMC and DIMJ inserts should be used for plunging applications only.

Boring Bars ID Turning and Grooving With Coolant

DHR/L 619

Through shank coolant

Use insert type: DIMC, DIMJ, DIPV

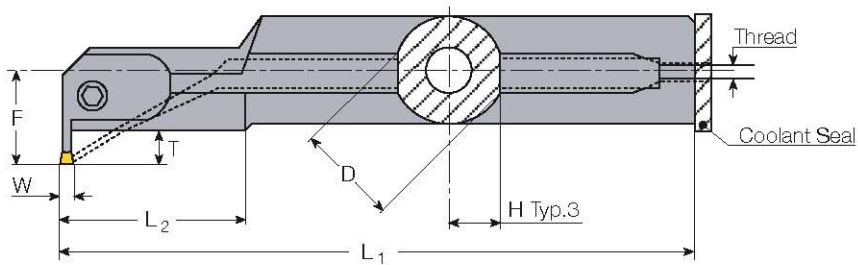
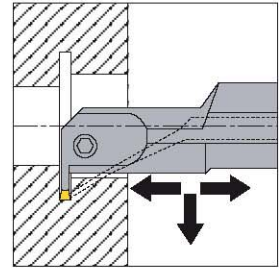

Right-hand shown

Designation	D	Min. Bore ØD	T Max.	σ _{0.2}	Dimensions W Range	F	L ₁	L ₂	H
DHR/L 619 25C 2	25	43	6.5	0.3	1.85-2.5	20	200	51	11.5
DHR/L 619 25C 3	25	52	8	0.5	2.8-3.6	20.8	200	51	11.5
DHR/L 619 25C 4	25	52	8	0.5	3.6-4.6	20.8	200	51	11.5

DIMC and DIMJ inserts should be used for plunging applications only.

Ⓜ Recommended cutting edge height above center for optimum results.

Seal Thread: Metric R1/8

When using the seal, bar can be shortened by 100mm max.

Boring bar supplied complete with lock screw, T20 torx wrench and seal, without insert.

Tool Blocks KGTBN for Operations for D Cut Blades

KGTBN

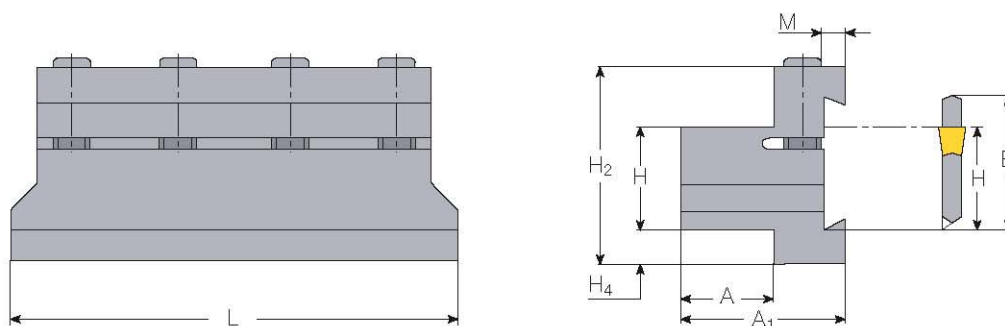

Designation	H	B	A	A ₁	H ₂	H ₄	M	L	Screw	Blade
KGTBN 20-5	20	26	19	33	38	8	4.0	87	S-M6x30	26
KGTBN 20-6	20	32	19	35	48	13	5.5	100	S-M6x40	32
KGTBN 25-6	25	32	20	36	48	8	5.5	110	S-M6x40	32

5 mm hex key supplied with block

Grades Chart

PVD Coated	<p>DC 120</p> <p>Very successful on stainless steel, cast iron, and nonferrous materials, good also for interrupted cuts. Has low wear resistance.</p>
PVD Coated	<p>DC 9235</p> <p>A TIN/TICN PVD coated tough grade, used for wide range of workpieces, at low to medium cutting speeds.</p>

Selection of Carbide Grades for Different Materials for Turning and Profiling

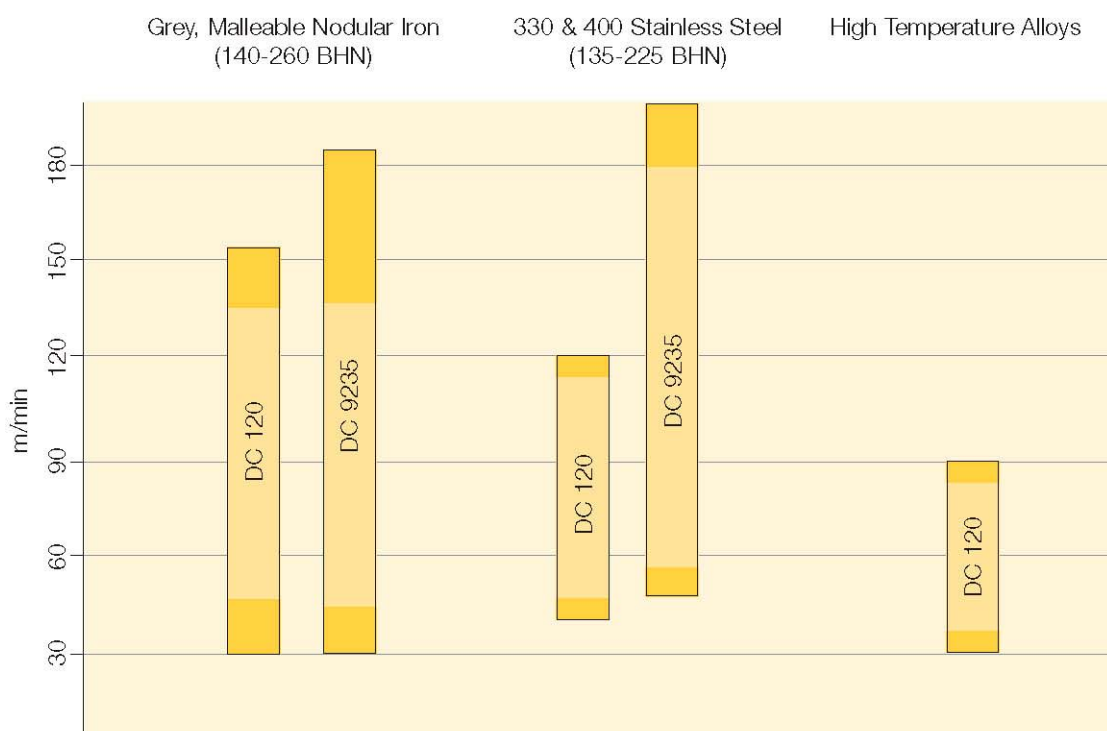
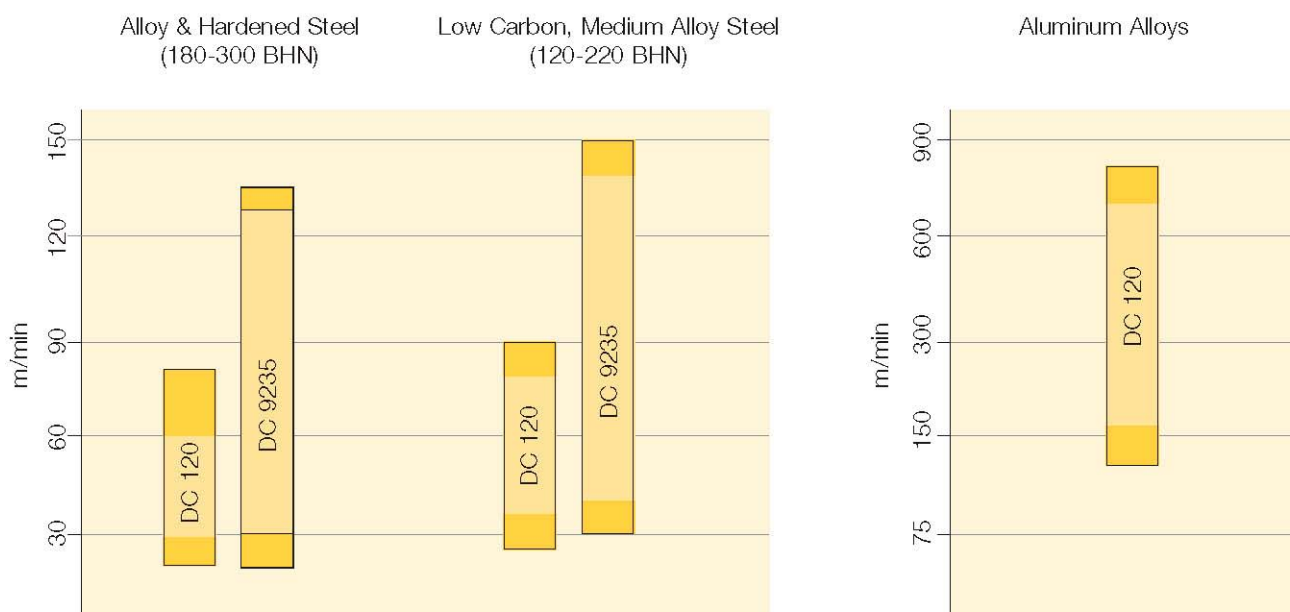

Normal Operation Range



Machining Conditions Turning with DIPV-Type Inserts (E-type)

Iron Base Alloys

**High-Temp.
Alloys**

Material Commercial Designation	Hardness	Cutting Speed m/min		
		0.10	0.15	0.20
V 75, A 286	Sol 81 Rb	50	35	25
Incoloy 800, 801	S & A 24-34 Rc	55	40	30
Austenitic Stainless Steel 302, 303, 304, 310 316, 321, 347	Annealed 135-175 HBN	65	55	50
Martensitic Stainless Steel 403, 405, 410, 420, 430, etc.	Annealed 135-175 HBN Q & T 28-35Rc	70	65	60
17-4 PH	Sol 28-35Rc	—	—	—
17-7 PH	S & A 36-40Rc	—	—	—
Maraging Steel 120, 180, 200, 250, 300, 350 Grade	Annealed 26-34Rc	—	—	—
120, 180 Grade	Maraged 38-45Rc	—	—	—
200, 250, 300 350 Grade	Maraged 50-52Rc	30	25	—

Titanium Base Alloys

Ti6-2-4-2	Annealed 32-38 Rc	55	50	45
Ti6Al-4V	Annealed 32-38 Rc	50	40	35
	S & A 38-42Rc	40	35	30
Ti6Al-6V-2Sn	Annealed 34-38Rc	45	40	35
Ti7Al-4Mo Ti8Al-1Mo-1V	S & A 40-44Rc	40	35	30
TiA55 Ti75A	Annealed 110-175HBN	160	155	150
Ti140A	Annealed 30-36Rc	50	45	40

Nickel Base Alloys

Astroloy, Rene 41	Sol 20-30Rc	—	25	20
Udimet 500, 700	S & A 32-42Rc	—	20	15
Inconel W, X, 702, 718	Sol 20-30Rc	—	25	20
M 252, Waspalloy	S & A 40-42Rc	—	20	15
Hastolloy B, C, X	Annealed 90-100Rb	—	30	25
Inconel 600	Cold drawn 24-34Rc	—	25	20
TD 2	Stress relieved 30Rc	—	65	60

Key:
S & A = Solution & Aging
Sol = Solution
Q&T = Quenched & Tempered

General Rules for Turning & Profiling With DIPV Inserts

Multi-Directional Operations/Turning & Grooving

The tools are able to operate in a sequence of turning and grooving operations. When changing direction from turning to grooving you need to give special consideration to the insert deflection.

During the directional change, you must release the side deflection by following the machining sequence as listed below:

After completing the longitudinal turning (1), but prior to plunging the groove, the side deflection must be released, (2). To do this, move the tool back approximately 0.1mm in the opposite direction. This will return the insert to the original position.

Only after the deflection has been released and the tool is perpendicular to the workpiece, can the grooving operation begin (3).

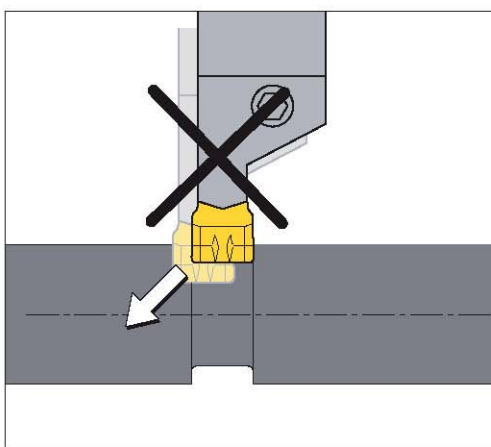
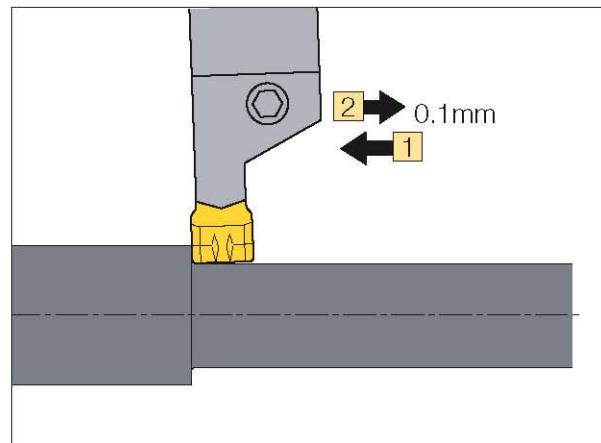
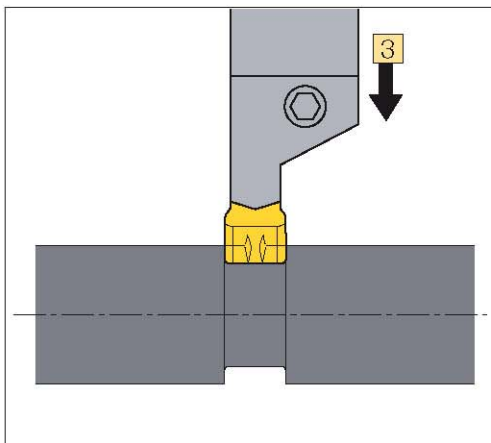

Diagonal cut is not recommended

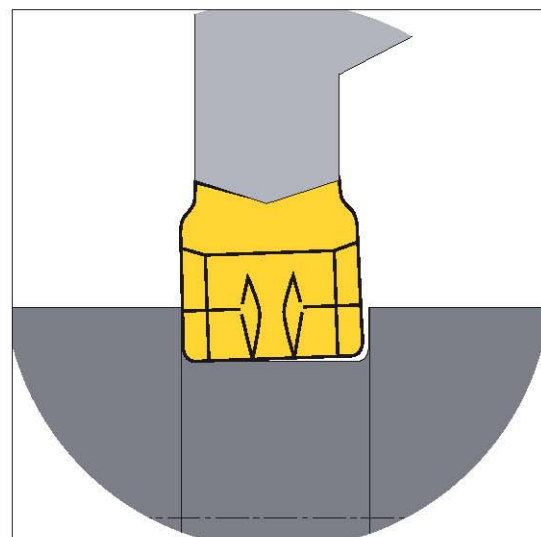

Insert deflection

General Recommendations

Insert Mounting

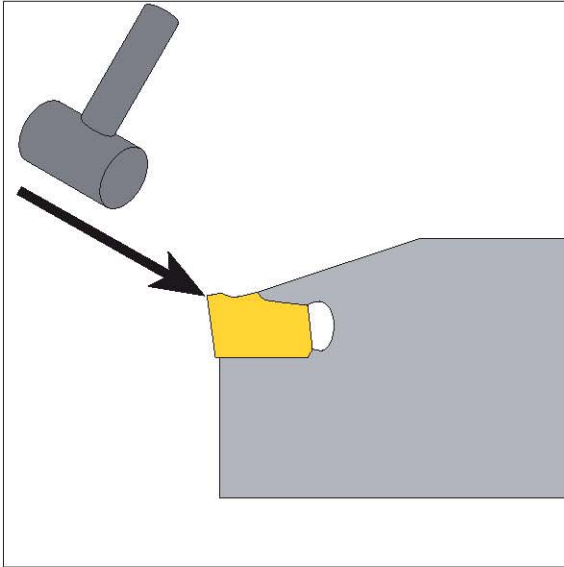

By hand or with plastic hammer

Insert Extraction

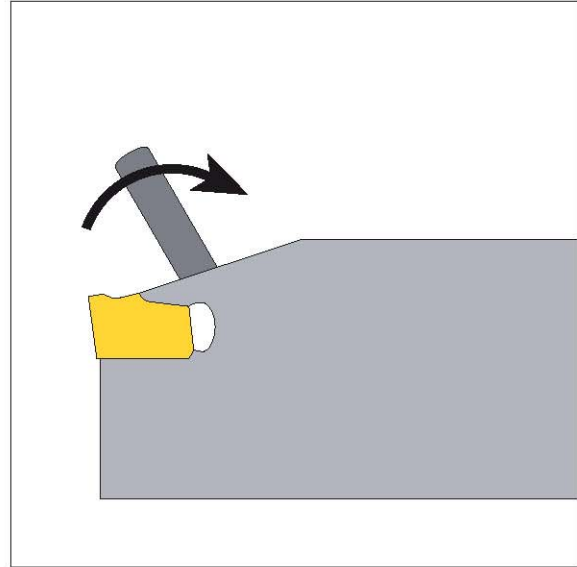

With extractor key

Boring and Profiling

Correct boring bar overhang

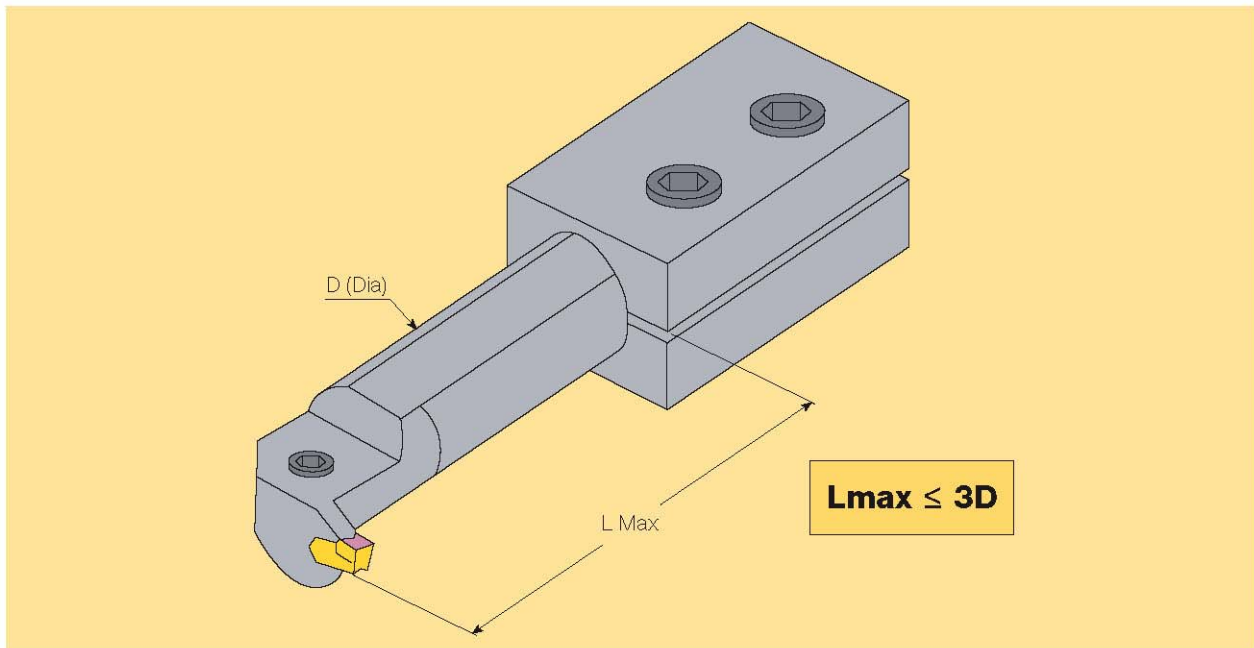



D Thread

Contents

Inserts

Partial Profile 60°	76
Partial Profile 55°	77
ISO, Metric	78, 79
UN.....	80, 81
BSW.....	82, 83
NPT.....	84

Toolholders

External	85
Boring Bars	86

Technical Data	87-91
-----------------------------	-------

Partial Profile 60°

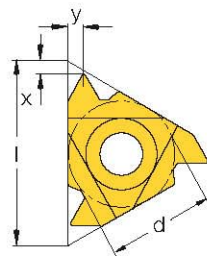
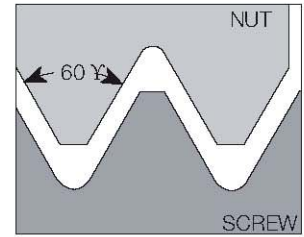

Standard Type

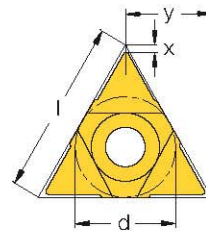

U-Type

External

Designation Right-Hand	Left-Hand	d	Pitch Range		Dimensions		
			mm	TPI	l	x	y
11 ER A 60	11 EL A 60	6.35	0.5-1.5	48-16	11	0.8	0.9
16 ER A 60	16 EL A 60		0.5-1.5	48-16			
16 ER G 60	16 EL G 60	9.53	1.75-3.0	14-8	16	1.2	1.7
16 ER AG 60	16 EL AG 60		0.5-3.0	48-8			
22 ER N 60	22 EL N 60	12.7	3.5-5.0	7-5	22	1.7	2.5
22 U EIRL U 60			5.5-8.0	4.5-3.25			
27 ER Q 60	27 EL Q 60	15.88	5.5-6.0	4.5-4	27	2.1	3.1
27 U EIRL U 60			6.5-9.0	4-2.75			

* Grade DC9800

Internal

Designation Right-Hand	Left-Hand	d	Pitch Range		Dimensions		
			mm	TPI	l	x	y
11 IR A 60	11 IL A 60	6.35	0.5-1.5	48-16	11	0.8	0.9
16 IR A 60	16 IL A 60		0.5-1.5	48-16			
16 IR G 60	16 IL G 60	9.53	1.75-3.0	14-8	16	1.2	1.7
16 IR AG 60	16 IL AG 60		0.5-3.0	48-8			
22 IR N 60	22 IL N 60	12.7	3.5-5.0	7-5	22	1.7	2.5
22 U EIRL U 60			5.5-8.0	4.5-3.25			
27 IR Q 60	27 IL Q 60	15.88	5.5-6.0	4.5-4	27	1.8	2.7
27 U EIRL U 60			6.5-9.0	4-2.75			

* Grade DC9800

Partial Profile 55°

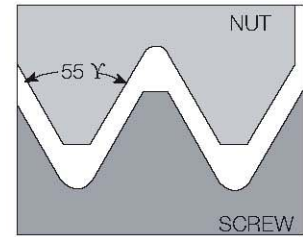
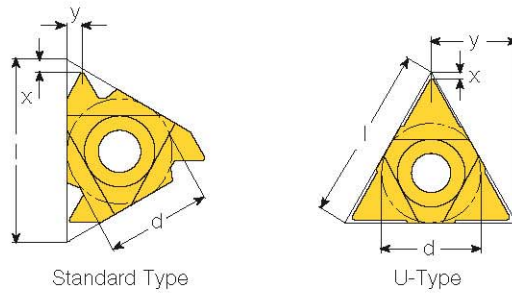

External

Designation		d	Pitch Range		Dimensions		
Right-Hand	Left-Hand		mm	TPI	l	x	y
11 ER A 55	11 EL A 55	6.35	0.5-1.5	48-16	11	0.8	0.9
16 ER A 55	16 EL A 55	9.53	0.5-1.5	48-16	16	0.8	0.9
16 ER G 55	16 EL G 55		1.75-3.0	14-8		1.2	1.7
16 ER AG 55	16 EL AG 55	12.7	0.5-3.0	48-8	22	1.2	1.7
22 ER N 55	22 EL N 55		3.5-5.0	7-5		1.7	2.5
	22 U EIRL U 55	15.88	5.5-8.0	4.5-3.25	27	0.9	11.0
27 ER Q 55	27 EL Q 55		5.5-6.0	4.5-4		2.0	2.9
	27 U EIRL U 55		6.5-9.0	4-2.75		1.2	13.7

* Grade DC9800

Internal

Designation		d	Pitch Range		Dimensions		
Right-Hand	Left-Hand		mm	TPI	l	x	y
11 IR A 55	11 IL A 55	6.35	0.5-1.5	48-16	11	0.8	0.9
16 IR A 55	16 IL A 55	9.53	0.5-1.5	48-16	16	0.8	0.9
16 IR G 55	16 IL G 55		1.75-3.0	14-8		1.2	1.7
16 IR AG 55	16 IL AG 55	12.7	0.5-3.0	48-8	22	1.2	1.7
22 IR N 55	22 IL N 55		3.5-5.0	7-5		1.7	2.5
	22 U EIRL U 55	15.88	5.5-8.0	4.5-3.25	27	0.9	11.0
27 IR Q 55	27 IL Q 55		5.5-6.0	4.5-4		2.0	2.9
	27 U EIRL U 55		6.5-9.0	4-2.75		1.2	13.7

* Grade DC9800

ISO Metric

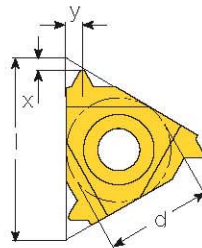
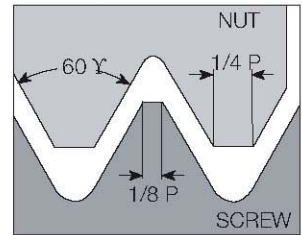

Right-Hand Shown

External

Designation		Pitch	Dimensions		
Right-Hand	Left-Hand	mm	l	x	y
11 ER 0.35 ISO	11 EL 0.35 ISO	0.35		0.8	0.4
11 ER 0.4 ISO	11 EL 0.4 ISO	0.4		0.7	0.4
11 ER 0.45 ISO	11 EL 0.45 ISO	0.45		0.7	0.4
11 ER 0.5 ISO	11 EL 0.5 ISO	0.5		0.6	0.6
11 ER 0.6 ISO	11 EL 0.6 ISO	0.6		0.6	0.6
11 ER 0.7 ISO	11 EL 0.7 ISO	0.7		0.6	0.6
11 ER 0.75 ISO	11 EL 0.75 ISO	0.75	6.35	0.6	0.6
11 ER 0.8 ISO	11 EL 0.8 ISO	0.8		0.6	0.6
11 ER 1.0 ISO	11 EL 1.0 ISO	1.0		0.7	0.7
11 ER 1.25 ISO	11 EL 1.25 ISO	1.25		0.8	0.9
11 ER 1.5 ISO	11 EL 1.5 ISO	1.5		0.8	1.0
11 ER 1.75 ISO	11 EL 1.75 ISO	1.75		0.8	1.1
16 ER 0.35 ISO	16 EL 0.35 ISO	0.35		0.8	0.4
16 ER 0.4 ISO	16 EL 0.4 ISO	0.4		0.7	0.4
16 ER 0.45 ISO	16 EL 0.45 ISO	0.45		0.7	0.4
16 ER 0.5 ISO	16 EL 0.5 ISO	0.5		0.6	0.6
16 ER 0.6 ISO	16 EL 0.6 ISO	0.6		0.6	0.6
16 ER 0.7 ISO	16 EL 0.7 ISO	0.7		0.6	0.6
16 ER 0.75 ISO	16 EL 0.75 ISO	0.75		0.6	0.6
16 ER 0.8 ISO	16 EL 0.8 ISO	0.8	9.53	0.6	0.6
16 ER 1.0 ISO	16 EL 1.0 ISO	1.0		0.7	0.7
16 ER 1.25 ISO	16 EL 1.25 ISO	1.25		0.8	0.9
16 ER 1.5 ISO	16 EL 1.5 ISO	1.50		0.8	1
16 ER 1.75 ISO	16 EL 1.75 ISO	1.75		0.9	1.2
16 ER 2.0 ISO	16 EL 2.0 ISO	2.0		1.0	1.3
16 ER 2.5 ISO	16 EL 2.5 ISO	2.5		1.1	1.5
16 ER 3.0 ISO	16 EL 3.0 ISO	3.0		1.2	1.6
22 ER 3.5 ISO	22 EL 3.5 ISO	3.5		1.6	2.3
22 ER 4.0 ISO	22 EL 4.0 ISO	4.0	12.7	1.5	2.3
22 ER 4.5 ISO	22 EL 4.5 ISO	4.5		1.7	2.4
22 ER 5.0 ISO	22 EL 5.0 ISO	5.0		1.7	2.5
27 ER 5.5 ISO	27 EL 5.5 ISO	5.5	15.88	1.9	2.7
27 ER 6.0 ISO	27 EL 6.0 ISO	6.0		2.0	2.9
22 U ERL 5.5 ISO		5.5	12.7	2.3	11
22 U ERL 6.0 ISO		6.0		2.6	11
27 U ERL 8.0 ISO		8.0	15.88	2.4	13.7

* Grade DC9800

ISO METRIC

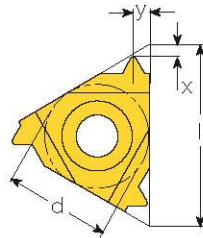

Right-Hand Shown

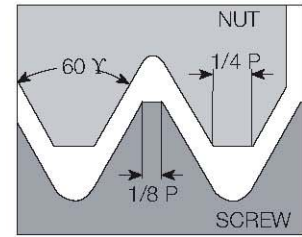

Internal

Designation		d	Pitch mm	Dimensions				
Right-Hand	Left-Hand			l	x	y		
11 IR 0.35 ISO	11 IL 0.35 ISO	6.35	0.35	11	0.8	0.3		
11 IR 0.4 ISO	11 IL 0.4 ISO		0.4		0.8	0.4		
11 IR 0.45 ISO	11 IL 0.45 ISO		0.45		0.8	0.4		
11 IR 0.5 ISO	11 IL 0.5 ISO		0.5		0.6	0.6		
11 IR 0.6 ISO	11 IL 0.6 ISO		0.6		0.6	0.6		
11 IR 0.7 ISO	11 IL 0.7 ISO		0.7		0.6	0.6		
11 IR 0.75 ISO	11 IL 0.75 ISO		0.75		0.6	0.6		
11 IR 0.8 ISO	11 IL 0.8 ISO		0.8		0.6	0.6		
11 IR 1.0 ISO	11 IL 1.0 ISO		1.0		0.6	0.7		
11 IR 1.25 ISO	11 IL 1.25 ISO		1.25		0.8	0.9		
11 IR 1.5 ISO	11 IL 1.5 ISO		1.5		0.8	1.0		
11 IR 1.75 ISO	11 IL 1.75 ISO		1.75		0.9	1.1		
16 IR 0.35 ISO	16 IL 0.35 ISO		9.53		0.35	16	0.8	0.3
16 IR 0.4 ISO	16 IL 0.4 ISO				0.4		0.8	0.4
16 IR 0.45 ISO	16 IL 0.45 ISO	0.45		0.8	0.4			
16 IR 0.5 ISO	16 IL 0.5 ISO	0.5		0.6	0.6			
16 IR 0.6 ISO	16 IL 0.6 ISO	0.6		0.6	0.6			
16 IR 0.7 ISO	16 IL 0.7 ISO	0.7		0.6	0.6			
16 IR 0.75 ISO	16 IL 0.75 ISO	0.75		0.6	0.6			
16 IR 0.8 ISO	16 IL 0.8 ISO	0.8		0.6	0.6			
16 IR 1.0 ISO	16 IL 1.0 ISO	1.0		0.6	0.7			
16 IR 1.25 ISO	16 IL 1.25 ISO	1.25		0.8	0.9			
16 IR 1.5 ISO	16 IL 1.5 ISO	1.5		0.8	1.0			
16 IR 1.75 ISO	16 IL 1.75 ISO	1.75		0.9	1.2			
16 IR 2.0 ISO	16 IL 2.0 ISO	2.0		1.0	1.3			
16 IR 2.5 ISO	16 IL 2.5 ISO	2.5		1.1	1.5			
16 IR 3.0 ISO	16 IL 3.0 ISO	3.0	1.1	1.5				
22 IR 3.5 ISO	22 IL 3.5 ISO	12.7	3.5	22	1.6	2.3		
22 IR 4.0 ISO	22 IL 4.0 ISO		4.0		1.6	2.3		
22 IR 4.5 ISO	22 IL 4.5 ISO		4.5		1.6	2.4		
22 IR 5.0 ISO	22 IL 5.0 ISO		5.0		1.6	2.3		
27 IR 5.5 ISO	27 IL 5.5 ISO	15.88	5.5	27	1.6	2.3		
27 IR 6.0 ISO	27 IL 6.0 ISO		6.0		1.8	2.5		
22 U IRL 5.5 ISO		12.7	5.5	22	2.4	11		
22 U IRL 6.0 ISO			6.0		2.1	11		
27 U IRL 8.0 ISO		15.88	8.0	27	2.4	13.7		

* Grade DC9800

UN

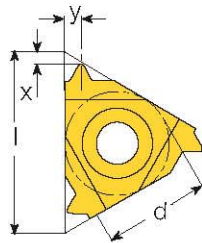

Right-Hand Shown

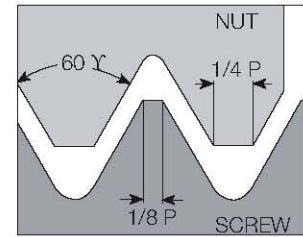

External

Designation Right-Hand	Left-Hand	d	Pitch TPI	Dimensions		
				l	x	y
11 ER 48 UN	11 EL 48 UN	6.35	48	11	0.6	0.6
11 ER 44 UN	11 EL 44 UN		44		0.6	0.6
11 ER 40 UN	11 EL 40 UN		40		0.6	0.6
11 ER 36 UN	11 EL 36 UN		36		0.6	0.6
11 ER 32 UN	11 EL 32 UN		32		0.6	0.6
11 ER 28 UN	11 EL 28 UN		28		0.6	0.7
11 ER 27 UN	11 EL 27 UN		27		0.7	0.8
11 ER 24 UN	11 EL 24 UN		24		0.7	0.8
11 ER 20 UN	11 EL 20 UN		20		0.8	0.9
11 ER 18 UN	11 EL 18 UN		18		0.8	1.0
11 ER 16 UN	11 EL 16 UN		16		0.9	1.1
11 ER 14 UN	11 EL 14 UN	14	0.9	1.1		
16 ER 72 UN	16 EL 72 UN	9.53	72	16	0.8	0.4
16 ER 64 UN	16 EL 64 UN		64		0.8	0.4
16 ER 56 UN	16 EL 56 UN		56		0.7	0.4
16 ER 48 UN	16 EL 48 UN		48		0.6	0.6
16 ER 44 UN	16 EL 44 UN		44		0.6	0.6
16 ER 40 UN	16 EL 40 UN		40		0.6	0.6
16 ER 36 UN	16 EL 36 UN		36		0.6	0.6
16 ER 32 UN	16 EL 32 UN		32		0.6	0.6
16 ER 28 UN	16 EL 28 UN		28		0.6	0.7
16 ER 27 UN	16 EL 27 UN		27		0.7	0.8
16 ER 24 UN	16 EL 24 UN		24		0.7	0.8
16 ER 20 UN	16 EL 20 UN	20	0.8	0.9		
16 ER 18 UN	16 EL 18 UN	18	0.8	1.0		
16 ER 16 UN	16 EL 16 UN	16	0.9	1.1		
16 ER 14 UN	16 EL 14 UN	14	1.0	1.2		
16 ER 13 UN	16 EL 13 UN	13	1.0	1.3		
16 ER 12 UN	16 EL 12 UN	12	1.1	1.4		
16 ER 11.5 UN	16 EL 11.5 UN	11.5	1.1	1.5		
16 ER 11 UN	16 EL 11 UN	11	1.1	1.5		
16 ER 10 UN	16 EL 10 UN	10	1.1	1.5		
16 ER 9 UN	16 EL 9 UN	9	1.2	1.7		
16 ER 8 UN	16 EL 8 UN	8	1.2	1.6		
22 ER 7 UN	22 EL 7 UN	12.7	7	22	1.6	2.3
22 ER 6 UN	22 EL 6 UN		6		1.6	2.3
22 ER 5 UN	22 EL 5 UN		5		1.7	2.5
27 ER 4.5 UN	27 EL 4.5 UN	15.88	4.5	27	1.9	2.7
27 ER 4 UN	27 EL 4 UN		4		2.1	3.0
22 U ERL 4.5 UN			4.5		2.0	11
22 U ERL 4 UN		4	2.0	11		
27 U ERL 3 UN		3	2.5	13.7		

* Grade DC9800

UN

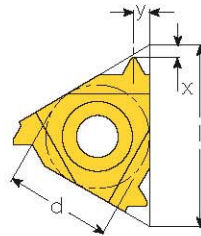

Right-Hand Shown

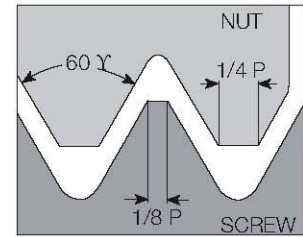

Internal

Designation		Pitch d	TPI	Dimensions		
Right-Hand	Left-Hand			l	x	y
11 IR 72 UN	11 IL 72 UN	6.35	72	11	0.8	0.3
11 IR 64 UN	11 IL 64 UN		64		0.8	0.4
11 IR 56 UN	11 IL 56 UN		56		0.7	0.4
11 IR 48 UN	11 IL 48 UN		48		0.6	0.6
11 IR 44 UN	11 IL 44 UN		44		0.6	0.6
11 IR 40 UN	11 IL 40 UN		40		0.6	0.6
11 IR 36 UN	11 IL 36 UN		36		0.6	0.6
11 IR 32 UN	11 IL 32 UN		32		0.6	0.6
11 IR 28 UN	11 IL 28 UN		28		0.6	0.7
11 IR 27 UN	11 IL 27 UN		27		0.7	0.8
11 IR 24 UN	11 IL 24 UN		24		0.7	0.8
11 IR 20 UN	11 IL 20 UN		20		0.8	0.9
11 IR 18 UN	11 IL 18 UN		18		0.8	1.0
11 IR 16 UN	11 IL 16 UN		16		0.9	1.1
11 IR 14 UN	11 IL 14 UN	14	0.9	1.1		
16 IR 72 UN	16 IL 72 UN	9.53	72	16	0.8	0.3
16 IR 64 UN	16 IL 64 UN		64		0.8	0.4
16 IR 56 UN	16 IL 56 UN		56		0.7	0.4
16 IR 48 UN	16 IL 48 UN		48		0.6	0.6
16 IR 44 UN	16 IL 44 UN		44		0.6	0.6
16 IR 40 UN	16 IL 40 UN		40		0.6	0.6
16 IR 36 UN	16 IL 36 UN		36		0.6	0.6
16 IR 32 UN	16 IL 32 UN		32		0.6	0.6
16 IR 28 UN	16 IL 28 UN		28		0.6	0.7
16 IR 27 UN	16 IL 27 UN		27		0.7	0.8
16 IR 24 UN	16 IL 24 UN		24		0.7	0.8
16 IR 20 UN	16 IL 20 UN		20		0.8	0.9
16 IR 18 UN	16 IL 18 UN		18		0.8	1.0
16 IR 16 UN	16 IL 16 UN		16		0.9	1.1
16 IR 14 UN	16 IL 14 UN	14	0.9	1.2		
16 IR 13 UN	16 IL 13 UN	13	1.0	1.3		
16 IR 12 UN	16 IL 12 UN	12	1.1	1.4		
16 IR 11.5 UN	16 IL 11.5 UN	11.5	1.1	1.5		
16 IR 11 UN	16 IL 11 UN	11	1.1	1.5		
16 IR 10 UN	16 IL 10 UN	10	1.1	1.5		
16 IR 9 UN	16 IL 9 UN	9	1.2	1.7		
16 IR 8 UN	16 IL 8 UN	8	1.1	1.5		
22 IR 7 UN	22 IL 7 UN	12.7	7	22	1.6	2.3
22 IR 6 UN	22 IL 6 UN		6		1.6	2.3
22 IR 5 UN	22 IL 5 UN		5		1.6	2.3
27 IR 4.5 UN	27 IL 4.5 UN	15.88	4.5	27	1.7	2.4
27 IR 4 UN	27 IL 4 UN		4		1.8	2.7
22 U IRL 4.5 UN		12.7	4.5	22	2.4	11
22 U IRL 4 UN			4		2.4	11
27 U IRL 3 UN		15.88	3	27	2.7	13.7

Grade DC9800 *

BSW

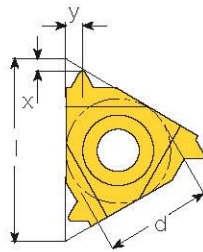

Right-Hand Shown

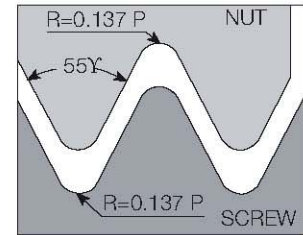

External

Designation		d	Pitch TPI	Dimensions				
Right-Hand	Left-Hand			l	x	y		
11 ER 40 W	11 EL 40 W	6.35	40	11	0.6	0.6		
11 ER 36 W	11 EL 36 W		36		0.6	0.6		
11 ER 32 W	11 EL 32 W		32		0.6	0.6		
11 ER 28 W	11 EL 28 W		28		0.6	0.7		
11 ER 26 W	11 EL 26 W		26		0.7	0.8		
11 ER 24 W	11 EL 24 W		24		0.7	0.8		
11 ER 22 W	11 EL 22 W		22		0.8	0.9		
11 ER 20 W	11 EL 20 W		20		0.8	0.9		
11 ER 19 W	11 EL 19 W		19		0.8	1.0		
11 ER 18 W	11 EL 18 W		18		0.8	1.0		
11 ER 16 W	11 EL 16 W		16		0.9	1.1		
11 ER 14 W	11 EL 14 W		14		1.0	1.2		
16 ER 40 W	16 EL 40 W		9.53		40	16	0.6	0.6
16 ER 36 W	16 EL 36 W				36		0.6	0.6
16 ER 32 W	16 EL 32 W	32		0.6	0.6			
16 ER 28 W	16 EL 28 W	28		0.6	0.7			
16 ER 26 W	16 EL 26 W	26		0.7	0.8			
16 ER 24 W	16 EL 24 W	24		0.7	0.8			
16 ER 22 W	16 EL 22 W	22		0.8	0.9			
16 ER 20 W	16 EL 20 W	20		0.8	0.9			
16 ER 19 W	16 EL 19 W	19		0.8	1.0			
16 ER 18 W	16 EL 18 W	18		0.8	1.0			
16 ER 16 W	16 EL 16 W	16		0.9	1.1			
16 ER 14 W	16 EL 14 W	14		1.0	1.2			
16 ER 12 W	16 EL 12 W	12		1.1	1.4			
16 ER 11 W	16 EL 11 W	11		1.1	1.5			
16 ER 10 W	16 EL 10 W	10	1.1	1.5				
16 ER 9 W	16 EL 9 W	9	1.2	1.7				
16 ER 8 W	16 EL 8 W	8	1.2	1.5				
22 ER 7 W	22 EL 7 W	12.7	7	22	1.6	2.3		
22 ER 6 W	22 EL 6 W		6		1.6	2.3		
22 ER 5 W	22 EL 5 W		5		1.7	2.4		
27 ER 4.5 W	27 EL 4.5 W	15.88	4.5	27	1.8	2.6		
27 ER 4 W	27 EL 4 W		4		2.0	2.9		
22 U ERL 4.5 W		12.7	4.5	22	2.3	1.1		
22 U ERL 4 W			4		1.8	1.1		
27 U ERL 3.50 W		15.88	3.5	27	2.1	13.7		
27 U ERL 3.25 W			3.25		2.0	13.7		
27 U ERL 3.00 W			3		2.3	13.7		
27 U ERL 2.75 W			2.75		2.4	13.7		

* Grade DC9800

BSW

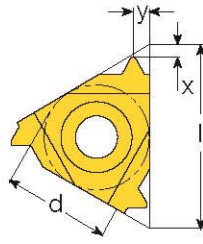

Right-Hand Shown

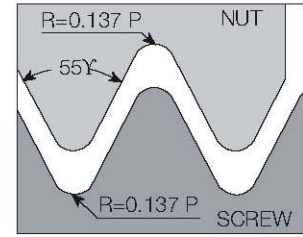

Internal

Designation		d	Pitch TPI	Dimensions		
Right-Hand	Left-Hand			l	X	Y
11 IR 36 W	11 IL 36 W	6.35	36	11	0.6	0.6
11 IR 32 W	11 IL 32 W		32		0.6	0.6
11 IR 28 W	11 IL 28 W		28		0.6	0.7
11 IR 26 W	11 IL 26 W		26		0.7	0.8
11 IR 24 W	11 IL 24 W		24		0.7	0.8
11 IR 22 W	11 IL 22 W		22		0.8	0.9
11 IR 20 W	11 IL 20 W		20		0.8	0.9
11 IR 19 W	11 IL 19 W		19		0.8	1.0
11 IR 18 W	11 IL 18 W		18		0.8	1.0
11 IR 16 W	11 IL 16 W		16		0.9	1.1
11 IR 14 W	11 IL 14 W		14		0.9	1.1
16 IR 72 W	16 IL 72 W	9.53	72	16	0.7	0.4
16 IR 60 W	16 IL 60 W		60		0.7	0.4
16 IR 56 W	16 IL 56 W		56		0.7	0.4
16 IR 48 W	16 IL 48 W		48		0.6	0.6
16 IR 40 W	16 IL 40 W		40		0.6	0.6
16 IR 36 W	16 IL 36 W		36		0.6	0.6
16 IR 32 W	16 IL 32 W		32		0.6	0.6
16 IR 28 W	16 IL 28 W		28		0.6	0.7
16 IR 26 W	16 IL 26 W		26		0.7	0.8
16 IR 24 W	16 IL 24 W		24		0.7	0.8
16 IR 22 W	16 IL 22 W		22		0.8	0.9
16 IR 20 W	16 IL 20 W		20		0.8	0.9
16 IR 19 W	16 IL 19 W		19		0.8	1.0
16 IR 18 W	16 IL 18 W		18		0.8	1.0
16 IR 16 W	16 IL 16 W		16		0.9	1.1
16 IR 14 W	16 IL 14 W		14		1.0	1.2
16 IR 12 W	16 IL 12 W		12		1.1	1.4
16 IR 11 W	16 IL 11 W		11		1.1	1.5
16 IR 10 W	16 IL 10 W		10		1.1	1.5
16 IR 9 W	16 IL 9 W		9		1.2	1.7
16 IR 8 W	16 IL 8 W	8	1.2	1.5		
22 IR 7 W	22 IL 7 W	12.7	7	22	1.6	2.3
22 IR 6 W	22 IL 6 W		6		1.6	2.3
22 IR 5 W	22 IL 5 W		5		1.7	2.4
27 IR 4.5 W	27 IL 4.5 W	15.88	4.5	27	1.8	2.6
27 IR 4 W	27 IL 4 W		4		2.0	2.9
22 U IRL 4.5 W		12.7	4.5	22	2.3	1.1
22 U IRL 4 W			4		1.8	1.1
27 U IRL 3.50 W		15.88	3.5	27	2.1	13.7
27 U IRL 3.25 W			3.25		2.0	13.7
27 U IRL 3.00 W			3		2.3	13.7
27 U IRL 2.75 W			2.75		2.4	13.7

* Grade DC9800

NPT

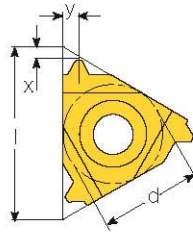

Right-Hand Shown

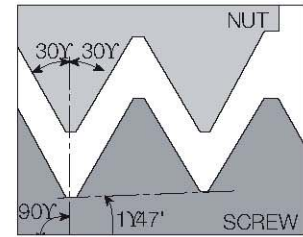

External

Designation		Pitch TPI	Dimensions			
Right-Hand	Left-Hand		d	l	x	y
16 ER 27 NPT	16 EL 27 NPT	27	9.53	16	0.7	0.8
16 ER 18 NPT	16 EL 18 NPT	18				
16 ER 14 NPT	16 EL 14 NPT	14				
16 ER 11.5 NPT	16 EL 11.5 NPT	11.5				
16 ER 8 NPT	16 EL 8 NPT	8				

* Grade DC9800

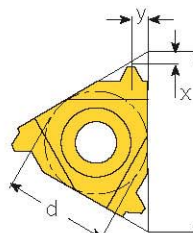

Right-Hand Shown

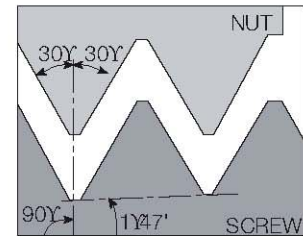

Internal

Designation		Pitch TPI	Dimensions			
Right-Hand	Left-Hand		d	l	x	y
11 IR 27 NPT	11 IL 27 NPT	27	6.35	11	0.7	0.8
11 IR 18 NPT	11 IL 18 NPT	18				
11 IR 14 NPT	11 IL 14 NPT	14				
16 IR 27 NPT	16 IL 27 NPT	27	9.53	16	0.7	0.8
16 IR 18 NPT	16 IL 18Q NPT	18				
16 IR 14 NPT	16 IL 14 NPT	14				
16 IR 11.5 NPT	16 IL 11.5 NPT	11.5				
16 IR 8 NPT	16 IL 8 NPT	8				

Grade DC9800 *

External Toolholders

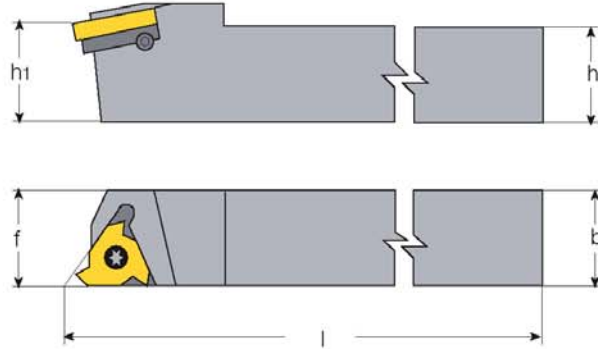

Designation	Dimensions			Spare Parts					
	$h=h_1$	b	l	f	Insert Screw	Anvil Screw	Torx Key	Anvil RH	LH
SER/L 2020 K16 -D	20	20	125	20					
SER/L 2525 M16 -D	25	25	150	25	S16	A16	K16	AE16	AI 16
SER/L 3232 P16 -D	32	32	170	32					

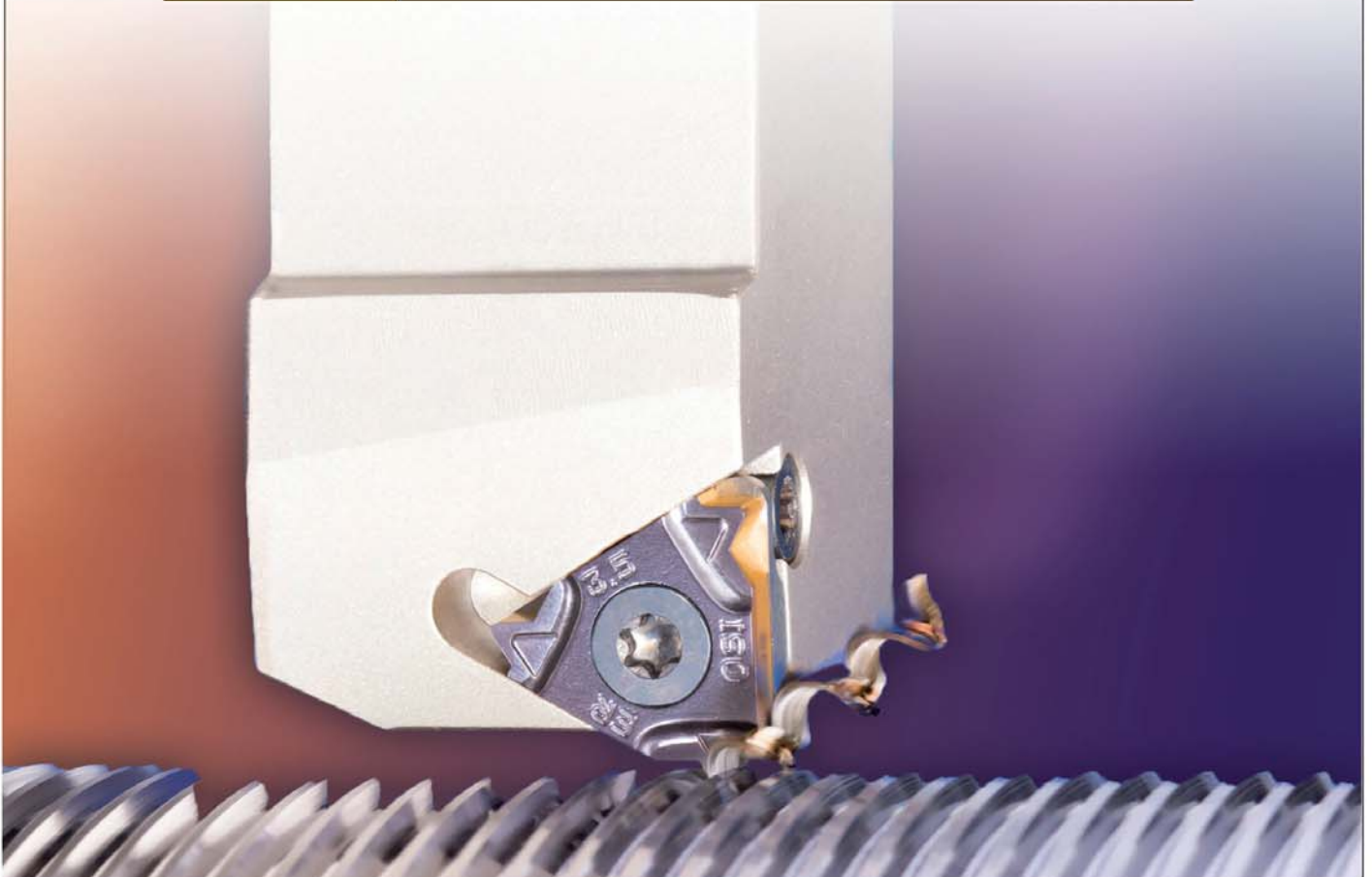

Boring Bars

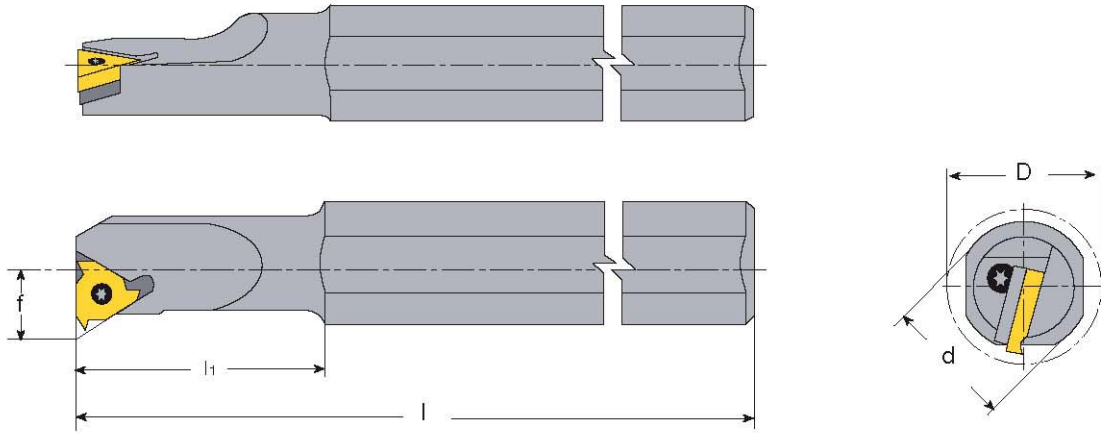

Designation	Dimensions					Spare Parts					
	d	l	l ₁	D _{min}	f	Insert Screw	Anvil Screw	Torx Key	Anvil RH	LH	
SIR/L 0010 H11 -D	10	100	-	12	7.4						
SIR/L 0010 K11 -D	16	125	25	12	6.5	S11	—	K11	—	—	
SIR/L 0013 M16 -D	16	150	32	16	10.0						
SIR/L 0016 P16 -D	20	170	40	19	11.4						
SIR/L 0020 P16 -D	20	170	—	24	13.4	S16	A16	K16	AI16	AE16	
SIR/L 0025 R16 -D	25	200	—	29	16.3						
SIR/L 0020 P22 -D	20	170	—	24	13.0						
SIR/L 0025 R22 -D	25	200	—	29	17.2						
SIR/L 0032 S22 -D	32	250	—	38	21.5	S22	A22	K22	AI22	AE22	
SIR/L 0040 T22 -D	40	300	—	46	25.8						

Selection of the Number of Cutting Passes

**EXTERNAL
RIGHT THREAD**

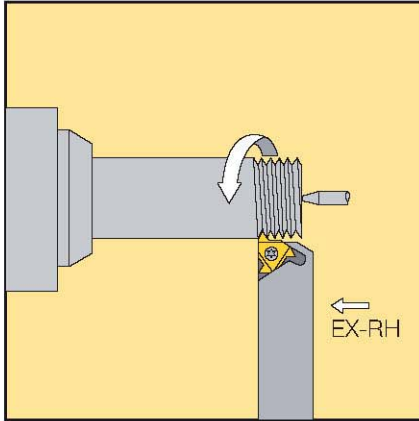

**EXTERNAL
LEFT THREAD**

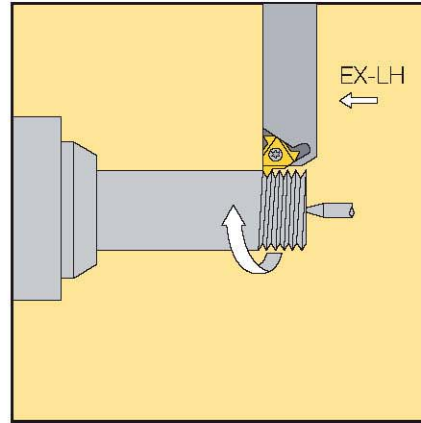

**INTERNAL
RIGHT THREAD**

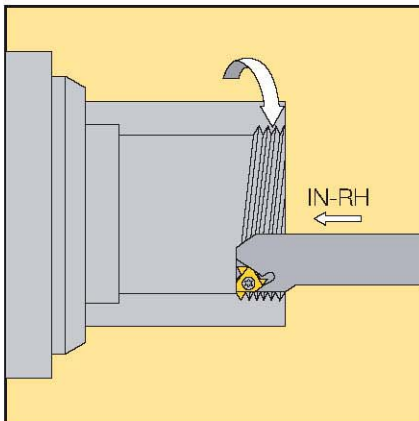

**INTERNAL
LEFT THREAD**

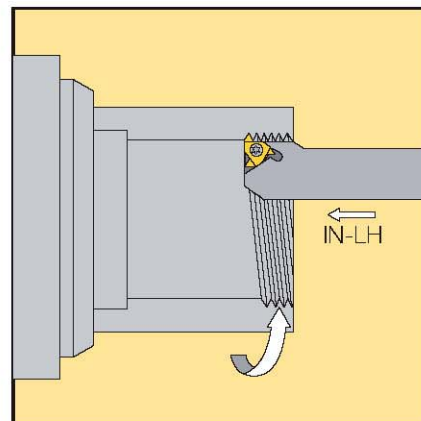

PITCH	MM	0.5	1.0	1.5	2.0	2.5	3.0	4.0	6.0
	TPI	48	24	16	12	10	8	6	4
NUMBER OF PASSES		6-3	9-4	11-5	13-6	15-7	17-8	20-10	22-11

Carbide Grades and Cutting Speed Selection Thread Helix Angle (λ) Standard and Slanted Anvils

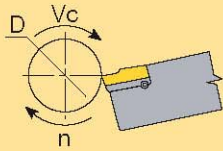

ISO

$V_C = [m/min]$
 $D = [mm]$
 $n = [RPM]$

ASA

$V_C = [ft/min]$
 $D = [inch]$
 $n = [RPM]$

Thread Helix Angle (λ)

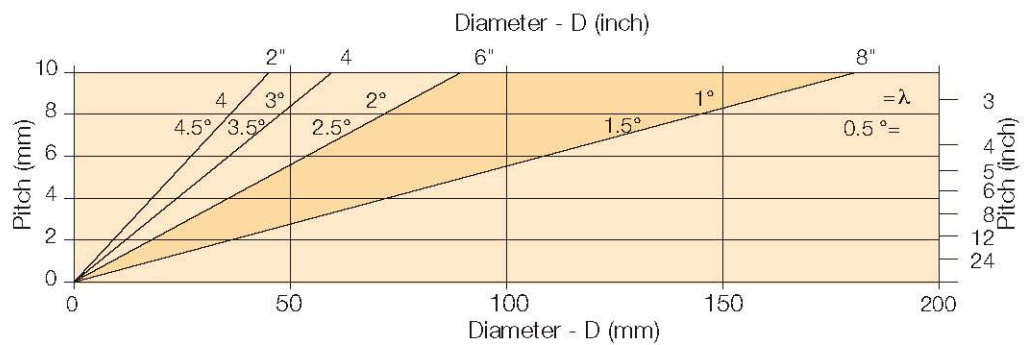
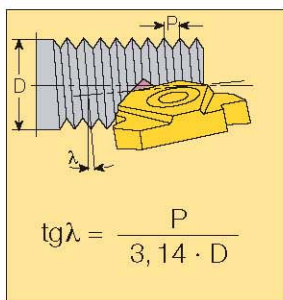

Standard and Slanted Anvils

P = Pitch in mm
 D = Effective diameter of thread (mm)
 λ = Angle of inclination

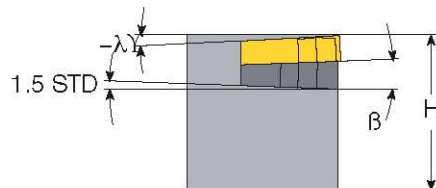

Negative Helix Angle
 Used when turning R.H. thread with L.H. holder or L.H. thread with R.H. holder

Note: H dimension remains constant for every anvil combination.

Thread Helix Angle λ		Standard						Negative Anvil	
		$>4^\circ$	$3^\circ-4^\circ$	$2^\circ-3^\circ$	$1^\circ-2^\circ$	$0^\circ-1^\circ$	-0.5°	-1.5°	
l (d)	Anvil Angle β Toolholder	4.5°	3.5°	2.5°	1.5°	0.5°			
16 (3/8)	EX RH OR IN LH	AE 16 +4.5	AE 16 +3.5	AE 16 +2.5	AE 16	AE 16 +0.5	AE 16 -0.5	AE 16 -1.5	
	EX LH OR IN RH	AI 16 +4.5	AI 16 +3.5	AI 16 +2.5	AI 16	AI 16 +0.5	AI 16 -0.5	AI 16 -1.5	
22 (1/2)	EX RH OR IN LH	AE 22 +4.5	AE 22 +3.5	AE 22 +2.5	AE 22	AE 22 +0.5	AE 22 -0.5	AE 22 -1.5	
	EX LH OR IN RH	AI 22 +4.5	AI 22 +3.5	AI 22 +2.5	AI 22	AI 22 +0.5	AI 22 -0.5	AI 22 -1.5	
27 (5/8)	EX RH OR IN LH	AE 27 +4.5	AE 27 +3.5	AE 27 +2.5	AE 27	AE 27 +0.5	AE 27 -0.5	AE 27 -1.5	
	EX LH OR IN RH	AI 27 +4.5	AI 27 +3.5	AI 27 +2.5	AI 27	AI 27 +0.5	AI 27 -0.5	AI 27 -1.5	
22U (1/2U)	EX RH OR IN LH	AE 22U+4.5	AE 22U+3.5	AE 22U+2.5	AE 22U	AE 22U+0.5	AE 22U-0.5	AE 22U -1.5	
	EX LH OR IN RH	AI 22U+4.5	AI 22U+3.5	AI 22U+2.5	AI 22U	AI 22U+0.5	AI 22U-0.5	AI 22U -1.5	
27U (5/8U)	EX RH OR IN LH	AE 27U+4.5	AE 27U+3.5	AE 27U+2.5	AE 27U	AE 27U+0.5	AE 27U-0.5	AE 27U -1.5	
	EX LH OR IN RH	AI 27U+4.5	AI 27U+3.5	AI 27U+2.5	AI 27U	AI 27U+0.5	AI 27U-0.5	AI 27U -1.5	

Threading Grades

DURACARB GRADE	ISO	PHYSICAL PROPERTIES	WORKPIECE MATERIAL	RECOMMENDED APPLICATIONS
DC9800	P15-P30 K20-K40 N15-N25	PVD Coated TiAlN	All types of steel, stainless steel, hard alloys	For machining heat resistant medium to high cutting speeds For interrupted cut and unfavorable conditions

ISO Application Range

ISO	P				K			
	10	20	30	40	05	10	20	30
Uncoated								
PVD Coated		DC 9800					DC 9800	

16 **E** **R** **12** **UN**

l	d
11	1/4
16	3/8
22	1/2
22U	1/2U
27	5/8
27U	5/8U

E EXTERNAL
I INTERNAL

R RIGHT-HAND
L LEFT-HAND

PARTIAL PROFILE			
	l	PITCH RANGE	
		mm	TPI
A	11	0.5 - 1.5	48 - 16
A	16	0.5 - 1.5	48 - 16
AG		0.5 - 3	48 - 8
G		1.75 - 3	14 - 8
N	22	3.5 - 5	7 - 5
U	27	3.5 - 8	4.5 - 3.25
Q		5.5 - 6	4.5 - 4
U	27	6.5 - 9	4 - 2.75

STANDARD

60= 60° PROFILE
55= 55° PROFILE
ISO (METRIC)
UN (AMERICAN UN)
W (BRITISH STANDARD WHITWORTH)
NPT (AMERICAN PIPE THREAD)

CARBIDE GRADES

COATED
DC 9800

FULL PROFILE PITCH BY NO.	
mm	TPI
8-0.35	2.75-72

S **E** **R** **2020** **K** **16**

SCREW CLAMPING

E = EXTERNAL
I = INTERNAL

R = RIGHT-HAND
L = LEFT-HAND

CROSS SECTION		
EXTERNAL TOOLHOLDERS SQUARE SHANK: METRIC: 2020 = 20 mm x 20 mm INCH 1500 = 1.5" x 1.5"		
INTERNAL TOOLHOLDERS ROUND SHANK: METRIC: 0025 = 25 mm DIAMETER INCH: 0750 = 0.75" DIAMETER		

LENGTH OF TOOLHOLDER		
	mm	INCH
D =	60	2.5
F =	80	3.25
H =	100	4.0
K =	125	5.0
L =	140	5.5
M =	150	6.0
P =	170	7.0
R =	200	8.0
S =	250	10.0
T =	300	12.0
U =	350	14.0
V =	400	16.0

POCKET SIZE		
	l (mm)	d (inch)
	11	1/4
	16	3/8
	22	1/2
	27	5/8
	22U	1/2U
	27U	5/8U

INSERT SIZE	INSERT SCREW	ANVIL SCREW	TORX KEY	ANVIL	
				RH	LH
11 (1/4*)	EXTERNAL INTERNAL	S 11		K 11	
16 (3/8*)	EXTERNAL INTERNAL	A 16 A 16	K 16 K 16	AE 16 AI 16	AI 16 AE 16
22 (1/2*)	EXTERNAL INTERNAL	S 22 S 22	K 22 K 22	AE 22 AI 22	AI 22 AE 22
22 U	EXTERNAL INTERNAL	S 22 S 22	K 22 K 22	AE 22U AI 22U	AI 22U AE 22U
27 (5/8*)	EXTERNAL INTERNAL	S 27 S 27	K 27 K 27	AE 27 AI 27	AI 27 AE 27
27U	EXTERNAL INTERNAL	S 27 S 27	K 27 K 27	AE 27U AI 27U	AI 27U AE 27U

Solutions	Problems							
	Premature Wear	Chipped Edge	Plastic Deformation	Built-up Edge	Broken Nose First Pass	Broken Nose After First Pass	Poor Surface Finish	Poor Chip Control
Increase RPM				●	●		●	
Reduce RPM	●	●	●				●	●
Increase Depth of Cut	●			●				
Reduce Depth of Cut		●	●		●	●	●	
Use Coated Grade	●	●	●	●				
Use Tougher Grade		●			●	●		
Modify Flank Infeed	●	●		●		●	●	●
Apply Coolant	●	●	●	●			●	●
Reselect Anvil	●					●	●	
Reduce Tool Overhang						●	●	
Check Turned Diameter	●		●		●			
Check Center Height	●				●		●	



Designation System of DEC-Drill

DEC D160S25 - 2D

1 2 3

1. Drill Diameter

- D160 → Ø 16.0 mm
- D210 → Ø 21.0 mm

2. Shank Length

- S25 → Ø 25.0 mm
- S32 → Ø 32.0 mm

3. Drilling Depth

- 2D → 2XD
- 3D → 3XD

Drill Programme

DEC-Drill

- Indexable Drill
- Internal coolant
- Diameter D12.5-D41mm
- Drilling Depth : 2XD, 3XD, 4XD

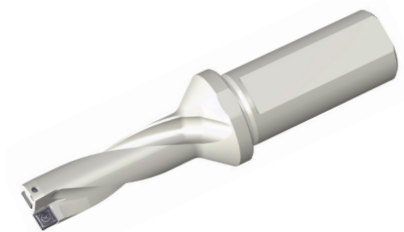

DEC-Drill Insert

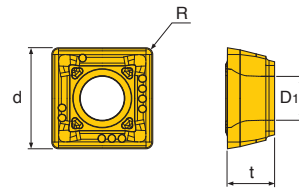

SPMX □□□□□ MG

Insert	Designation	Dimension(mm)				Diameter(mm)	Grade	
		d	t	R	ØD ₁		DC9800	DC9235
	SPMX 05T204 MG	5	2.68	0.4	2.25	TS 20043I/HG-P	●	●
	06T204 MG	6	2.8	0.4	2.61	TS 22052I/HG	●	●
	070308 MG	7.94	3.5	0.8	2.85	TS 25064I	●	●
	09T308 MG	9.8	3.8	0.8	4.05	TS 35088I	●	●
	11T308 MG	11.5	4.3	0.8	4.45	TS 40093I	●	●

DEC-Drill Drilling Depth: 2XD

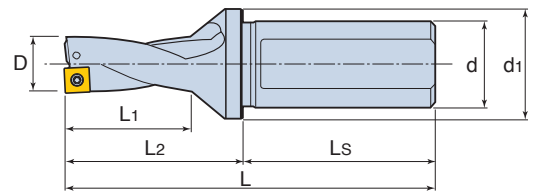
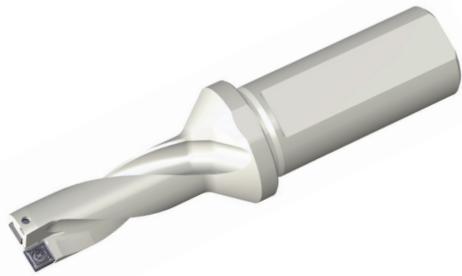

Designation	Dimension(mm)							Insert	Component				Torque (N·cm)
	D	d	d1	LS	L2	L1	L		Screw	Wrench	Plug	Set Screw	
DEC D125S20-2D	12.5	20	25	50	44	26	94	SPMX 05T204 MG	TS 20043I/ HG-P	TD 6P	SL 20 M	-	50-70
DEC D130S20-2D	13	20	25	50	44	26	94						50-70
DEC D135S20-2D	13.5	20	25	50	46	28	96						50-70
DEC D140S20-2D	14	20	25	50	46	28	96						50-70
DEC D145S20-2D	14.5	20	25	50	49	30	99						50-70
DEC D150S20-2D	15	20	25	50	49	30	99						50-70
DEC D155S25-2D	15.5	25	32	56	52	32	108	SPMX 06T204 MG	TS 22052I/HG	TD 7	SL 25	-	80-100
DEC D160S25-2D	16	25	32	56	52	32	108						80-100
DEC D165S25-2D	16.5	25	32	56	54	34	110						80-100
DEC D170S25-2D	17	25	32	56	54	34	110						80-100
DEC D175S25-2D	17.5	25	32	56	57	36	113						80-100
DEC D180S25-2D	18	25	32	56	57	36	113						80-100
DEC D185S25-2D	18.5	25	32	56	59	38	115						80-100
DEC D190S25-2D	19	25	32	56	59	38	115						80-100
DEC D195S25-2D	19.5	25	32	56	63	40	119						80-100
DEC D200S25-2D	20	25	32	56	63	40	119						80-100
DEC D205S25-2D	20.5	25	32	56	65	42	121						80-100
DEC D210S25-2D	21	25	32	56	65	42	121						80-100
DEC D215S25-2D	21.5	25	32	56	67	44	123						80-100
DEC D220S25-2D	22	25	32	56	67	44	123						SPMX 070308 MG
DEC D225S25-2D	22.5	25	45	56	71	46	127	100-120					
DEC D230S25-2D	23	25	45	56	71	46	127	100-120					
DEC D235S25-2D	23.5	25	45	56	74	48	130	100-120					
DEC D240S25-2D	24	25	45	56	74	48	130	100-120					
DEC D245S32-2D	24.5	32	45	60	77	50	137	100-120					
DEC D250S32-2D	25	32	45	60	77	50	137	100-120					
DEC D255S32-2D	25.5	32	45	60	79	52	139	100-120					
DEC D260S32-2D	26	32	45	60	79	52	139	100-120					
DEC D265S32-2D	26.5	32	45	60	81	54	141	100-120					
DEC D270S32-2D	27	32	45	60	81	54	141	100-120					
DEC D275S32-2D	27.5	32	45	60	84	56	144	100-120					
DEC D280S32-2D	28	32	45	60	84	56	144	SPMX 09T308 MG	TS 35088I	TD10	-	300-340	
DEC D285S32-2D	28.5	32	45	60	86	58	146					300-340	
DEC D290S32-2D	29	32	45	60	86	58	146					300-340	
DEC D295S32-2D	29.5	32	55	60	91	60	151					300-340	
DEC D300S32-2D	30	32	55	60	91	60	151					300-340	
DEC D305S32-2D	30.5	32	55	60	94	62	154					300-340	
DEC D310S32-2D	31	32	55	60	94	62	154					300-340	
DEC D315S32-2D	31.5	32	55	60	96	64	156					300-340	
DEC D320S32-2D	32	32	55	60	96	64	156					300-340	
DEC D325S32-2D	32.5	32	55	60	99	66	159					300-340	
DEC D330S32-2D	33	32	55	60	99	66	159	300-340					
DEC D340S40-2D	34	40	55	70	101	68	171	SPMX 11T308 MG	TS 40093I	TD 15	-	450-520	
DEC D350S40-2D	35	40	55	70	104	70	174					450-520	
DEC D360S40-2D	36	40	55	70	107	72	177					450-520	
DEC D370S40-2D	37	40	55	70	110	74	180					450-520	
DEC D380S40-2D	38	40	55	70	113	76	183					450-520	
DEC D390S40-2D	39	40	55	70	115	78	185					450-520	
DEC D400S40-2D	40	40	60	70	118	80	188					450-520	
DEC D410S40-2D	41	40	60	70	121	82	191					450-520	
												SS M6X1X6	450-520
												SS M8X1.25X8	450-520

DEC-Drill Drilling Depth: 3XD

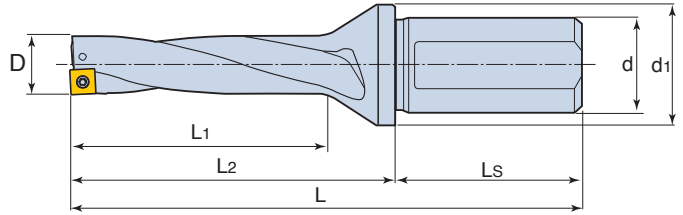
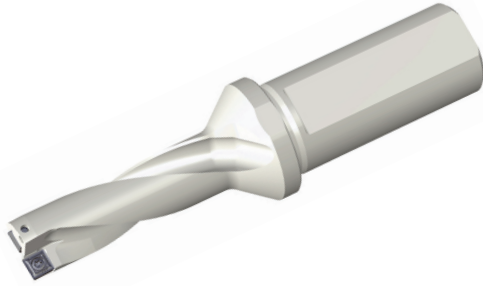

Designation	Dimension(mm)							Insert	Component				Torque (N·cm)
	D	d	d1	LS	L2	L1	L		Screw	Wrench	Plug	Set Screw	
DEC D125S20-3D	12.5	20	25	50	57	39	107	SPMX 05T204 MG	TS 20043I/ HG-P	TD 6P	SL 20 M	-	50-70
DEC D130S20-3D	13	20	25	50	57	39	107						50-70
DEC D135S20-3D	13.5	20	25	50	60	42	110						50-70
DEC D140S20-3D	14	20	25	50	60	42	110						50-70
DEC D145S20-3D	14.5	20	25	50	64	45	114						50-70
DEC D150S20-3D	15	20	25	50	64	45	114						50-70
DEC D155S25-3D	15.5	25	32	56	68	48	124	SPMX 06T204 MG	TS 22052I/HG	TD 7	SL 25	-	80-100
DEC D160S25-3D	16	25	32	56	68	48	124						80-100
DEC D165S25-3D	16.5	25	32	56	71	51	127						80-100
DEC D170S25-3D	17	25	32	56	71	51	127						80-100
DEC D175S25-3D	17.5	25	32	56	75	54	131						80-100
DEC D180S25-3D	18	25	32	56	75	54	131						80-100
DEC D185S25-3D	18.5	25	32	56	78	57	134						80-100
DEC D190S25-3D	19	25	32	56	78	57	134						80-100
DEC D195S25-3D	19.5	25	32	56	83	60	139						80-100
DEC D200S25-3D	20	25	32	56	83	60	139						80-100
DEC D205S25-3D	20.5	25	32	56	86	63	142						80-100
DEC D210S25-3D	21	25	32	56	86	63	142						80-100
DEC D215S25-3D	21.5	25	32	56	89	66	145	SPMX 070308 MG	TS 25064I	TD 8	-	80-100	
DEC D220S25-3D	22	25	32	56	89	66	145					100-120	
DEC D225S25-3D	22.5	25	45	56	94	69	150					100-120	
DEC D230S25-3D	23	25	45	56	94	69	150					100-120	
DEC D235S25-3D	23.5	25	45	56	98	72	154					100-120	
DEC D240S25-3D	24	25	45	56	98	72	154					100-120	
DEC D245S32-3D	24.5	32	45	60	102	75	162					100-120	
DEC D250S32-3D	25	32	45	60	102	75	162					100-120	
DEC D255S32-3D	25.5	32	45	60	105	78	165					100-120	
DEC D260S32-3D	26	32	45	60	105	78	165					100-120	
DEC D265S32-3D	26.5	32	45	60	108	81	168	100-120					
DEC D270S32-3D	27	32	45	60	108	81	168	100-120					
DEC D275S32-3D	27.5	32	45	60	112	84	172	100-120					
DEC D280S32-3D	28	32	45	60	112	84	172	SPMX 09T308 MG	TS 35088I	TD10	-	SS M6X1X6	100-120
DEC D285S32-3D	28.5	32	45	60	115	87	171					300-340	
DEC D290S32-3D	29	32	45	60	115	87	175					300-340	
DEC D295S32-3D	29.5	32	55	60	121	90	181					300-340	
DEC D300S32-3D	30	32	55	60	121	90	181					300-340	
DEC D305S32-3D	30.5	32	55	60	125	93	185					300-340	
DEC D310S32-3D	31	32	55	60	125	93	185					300-340	
DEC D315S32-3D	31.5	32	55	60	128	96	188					300-340	
DEC D320S32-3D	32	32	55	60	128	96	188					300-340	
DEC D325S32-3D	32.5	32	55	60	132	99	192					300-340	
DEC D330S32-3D	33	32	55	60	132	99	192	300-340					
DEC D340S40-3D	34	40	55	70	135	102	205	SPMX 11T308 MG	TS 40093I	TD 15	-	SS M6X1X6	450-520
DEC D350S40-3D	35	40	55	70	139	105	209					450-520	
DEC D360S40-3D	36	40	55	70	143	108	213					450-520	
DEC D370S40-3D	37	40	55	70	147	111	217					450-520	
DEC D380S40-3D	38	40	55	70	151	114	221					450-520	
DEC D390S40-3D	39	40	55	70	154	117	224					450-520	
DEC D400S40-3D	40	40	60	70	158	120	228					450-520	
DEC D410S40-3D	41	40	60	70	162	123	232					450-520	
												SS M8X1.25X8	450-520
													450-520

DEC-Drill Drilling Depth: 4XD

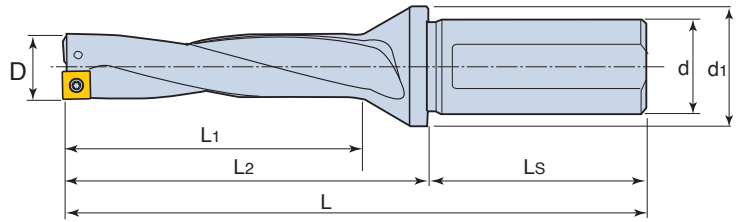
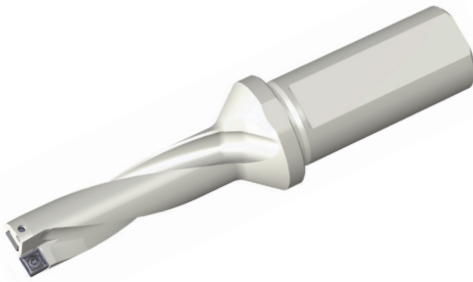

Designation	Dimension(mm)							Insert	Component				Torque (N·cm)
	D	d	d1	LS	L2	L1	L		Screw	Wrench	Plug	Set Screw	
DEC D125S20-4D	12.5	20	25	50	70	52	120	SPMX 05T204 MG	TS 20043I/ HG-P	TD 6P	SL 20 M	-	50-70
DEC D130S20-4D	13	20	25	50	70	52	120						50-70
DEC D135S20-4D	13.5	20	25	50	74	56	124						50-70
DEC D140S20-4D	14	20	25	50	74	56	124						50-70
DEC D145S20-4D	14.5	20	25	50	79	60	129						50-70
DEC D150S20-4D	15	20	25	50	79	60	129	50-70					
DEC D155S25-4D	15.5	25	32	56	84	64	140	SPMX 06T204 MG	TS 22052I/HG	TD 7	SL 25	-	80-100
DEC D160S25-4D	16	25	32	56	84	64	140						80-100
DEC D165S25-4D	16.5	25	32	56	88	68	144						80-100
DEC D170S25-4D	17	25	32	56	88	68	144						80-100
DEC D175S25-4D	17.5	25	32	56	93	72	149						80-100
DEC D180S25-4D	18	25	32	56	93	72	149						80-100
DEC D185S25-4D	18.5	25	32	56	97	76	153						80-100
DEC D190S25-4D	19	25	32	56	97	76	153						80-100
DEC D195S25-4D	19.5	25	32	56	103	80	159						80-100
DEC D200S25-4D	20	25	32	56	103	80	159						80-100
DEC D205S25-4D	20.5	25	32	56	107	84	163	80-100					
DEC D210S25-4D	21	25	32	56	107	84	163	80-100					
DEC D215S25-4D	21.5	25	32	56	111	88	167	80-100					
DEC D220S25-4D	22	25	32	56	111	88	167	SPMX 070308 MG	TS 25064I	TD 8	-	100-120	
DEC D225S25-4D	22.5	25	45	56	117	92	173					100-120	
DEC D230S25-4D	23	25	45	56	117	92	173					100-120	
DEC D235S25-4D	23.5	25	45	56	122	96	178					100-120	
DEC D240S25-4D	24	25	45	56	122	96	178					100-120	
DEC D245S32-4D	24.5	32	45	60	127	100	187					100-120	
DEC D250S32-4D	25	32	45	60	127	100	187					100-120	
DEC D255S32-4D	25.5	32	45	60	131	104	191					100-120	
DEC D260S32-4D	26	32	45	60	131	104	191					100-120	
DEC D265S32-4D	26.5	32	45	60	135	108	195					100-120	
DEC D270S32-4D	27	32	45	60	135	108	195	100-120					
DEC D275S32-4D	27.5	32	45	60	140	112	200	100-120					
DEC D280S32-4D	28	32	45	60	140	112	200	SPMX 09T308 MG	TS 35088I	TD10	-	300-340	
DEC D285S32-4D	28.5	32	45	60	144	116	204					300-340	
DEC D290S32-4D	29	32	45	60	144	116	204					300-340	
DEC D295S32-4D	29.5	32	55	60	151	120	211					300-340	
DEC D300S32-4D	30	32	55	60	151	120	211					300-340	
DEC D305S32-4D	30.5	32	55	60	156	124	216					300-340	
DEC D310S32-4D	31	32	55	60	156	124	216					300-340	
DEC D315S32-4D	31.5	32	55	60	160	128	220					300-340	
DEC D320S32-4D	32	32	55	60	160	128	220					300-340	
DEC D325S32-4D	32.5	32	55	60	165	132	225					300-340	
DEC D330S32-4D	33	32	55	60	165	132	225	300-340					
DEC D340S40-4D	34	40	55	70	169	136	239	SPMX 11T308 MG	TS 40093I	TD 15	-	450-520	
DEC D350S40-4D	35	40	55	70	174	140	244					450-520	
DEC D360S40-4D	36	40	55	70	179	144	249					450-520	
DEC D370S40-4D	37	40	55	70	184	148	254					450-520	
DEC D380S40-4D	38	40	55	70	189	152	259					450-520	
DEC D390S40-4D	39	40	55	70	193	156	253					450-520	
DEC D400S40-4D	40	40	60	70	198	160	268					450-520	
DEC D410S40-4D	41	40	60	70	203	164	273					450-520	
												SS M6X1X6	450-520
												SS M8X1.25X8	450-520

DEC-Drill Cutting Condition

ISO	Workpiece Material	Vc (m/min)	Feed (mm/rev)		
			Ø16 - Ø21.5	Ø22 - Ø27.5	Ø28 - Ø33
P	Low Carbon Steel (- 0.3% C)	180 - 240	0.06 - 0.10	0.06 - 0.12	0.07 - 0.13
	Carbon Steel (0.3% C-)	150 - 220	0.08 - 0.15	0.10 - 0.18	0.12 - 0.22
	Alloy Steel (- HB300)	140 - 200	0.08 - 0.14	0.10 - 0.18	0.12 - 0.22
	Alloy Steel (HB300-)	120 - 180	0.08 - 0.15	0.10 - 0.20	0.12 - 0.23
M	Stainless Steel	150 - 220	0.06 - 0.12	0.08 - 0.15	0.09 - 0.16
K	Cast Iron	160 - 240	0.08 - 0.16	0.12 - 0.20	0.15 - 0.25
	Ductile Cast Iron	120 - 200	0.08 - 0.15	0.10 - 0.18	0.12 - 0.20
N	Aluminum	250 - 350	0.08 - 0.15	0.10 - 0.20	0.12 - 0.22
S	Titanium Alloy (Ti 6Al)	30 - 60	0.06 - 0.14	0.08 - 0.18	0.10 - 0.22

Flex Head Drills Drilling Depth 1.5xD

Range $\phi 10$ to **19.9** for GHDP Inserts

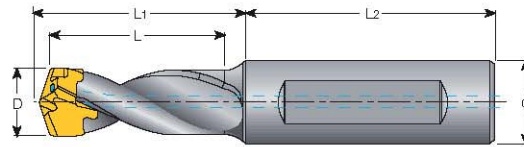

DHM 1.5XD

D ⁽¹⁾ Range	L	Designation	d	L ₁	L ₂	Pocket Size	Key	Drilling Heads
10-10.9	15	DHM1.5 100-015-16B	16	31.0	48	10	K DHM-10	GHDP GHDM GHDK GHDN
11-11.9	17	DHM1.5 110-017-16B	16	34.1	48	11	K DHM-11	
12-12.9	18	DHM1.5 120-018-16B	16	36.9	48	12	K DHM-12	
13-13.9	20	DHM1.5 130-020-16B	16	39.6	48	13	K DHM-13	
14-14.9	21	DHM1.5 140-021-16B	16	42.3	48	14	K DHM-14	
15-15.9	23	DHM1.5 150-023-20B	20	45.0	50	15	K DHM-15	
16-16.9	24	DHM1.5 160-024-20B	20	47.9	50	16	K DHM-16	
17-17.9	26	DHM1.5 170-026-20B	20	50.5	50	17	K DHM-17	
18-18.9	27	DHM1.5 180-027-25B	25	53.4	56	18	K DHM-18	
19-19.9	29	DHM1.5 190-029-25B	25	56.2	56	19	K DHM-19	

For drilling heads, see page 101.

Hole tolerance: D+0.02 in average conditions. However, it can be higher or lower according to machine and tooling conditions.

Flex Head Drills Drilling Depth 3xD

Range $\phi 10$ to **19.9** for GHDP Inserts

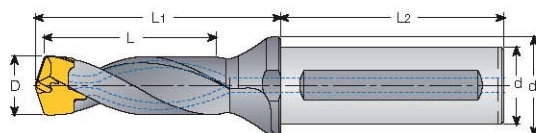

DHM 3XD

$\phi D^{(1)}$ Range	L	Designation	d	d ₁	L ₁	L ₂	Pocket Size	Key	Drilling Heads
10-10.9	30	DHM3 100-030-16A	16	20	46.0	48	10	K DHM-10	GHDP GHDM GHDK GHDN
11-11.9	33	DHM3 110-033-16A	16	20	50.6	48	11	K DHM-11	
12-12.9	36	DHM3 120-036-16A	16	20	54.9	48	12	K DHM-12	
13-13.9	39	DHM3 130-039-16A	16	20	59.1	48	13	K DHM-13	
14-14.9	42	DHM3 140-042-16A	16	20	63.4	48	14	K DHM-14	
15-15.9	45	DHM3 150-045-20A	20	25	67.5	50	15	K DHM-15	
16-16.9	48	DHM3 160-048-20A	20	25	71.9	50	16	K DHM-16	
17-17.9	51	DHM3 170-051-20A	20	25	76.2	50	17	K DHM-17	
18-18.9	54	DHM3 180-054-25A	25	32	80.5	56	18	K DHM-18	
19-19.9	57	DHM3 190-057-25A	25	32	84.8	56	19	K DHM-19	

⁽¹⁾ Do not mount smaller drilling heads than specified range for drill body.

For drilling heads, see page 101.

Hole tolerance: D+0.05 in average conditions. However, it can be higher or lower according to machine and tooling conditions.

Flex Head Drills Drilling Depth 5xD

Range $\phi 10$ to $\phi 19.9$ for GHDP Inserts

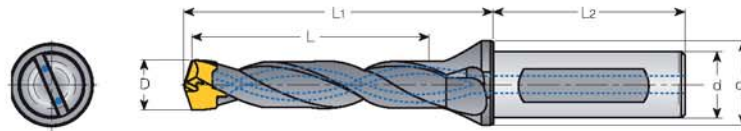

DHM 5XD

$\phi D(1)$ Range	L	Designation	d	d ₁	L ₁	L ₂	Pocket Size	Key	Drilling Heads
10-10.9	50	DHM5 100-050-16A	16	20	66.0	48	10	K DHM-10	GHDP GHDM GHDK GHDN
11-11.9	55	DHM5 110-055-16A	16	20	72.6	48	11	K DHM-11	
12-12.9	60	DHM5 120-060-16A	16	20	78.9	48	12	K DHM-12	
13-13.9	65	DHM5 130-065-16A	16	20	85.1	48	13	K DHM-13	
14-14.9	70	DHM5 140-070-16A	16	20	91.4	48	14	K DHM-14	
15-15.9	75	DHM5 150-075-20A	20	25	97.5	50	15	K DHM-15	
16-16.9	80	DHM5 160-080-20A	20	25	103.9	50	16	K DHM-16	
17-17.9	85	DHM5 170-085-20A	20	25	110.2	50	17	K DHM-17	
18-18.9	90	DHM5 180-090-25A	25	32	116.5	56	18	K DHM-18	
19-19.9	95	DHM5 190-095-25A	25	32	122.8	56	19	K DHM-19	

⁽¹⁾ Do not mount smaller drilling heads than specified range for drill body.
For drilling heads, see page 101.

Hole tolerance: D+0.05 in average conditions. However, it can be higher or lower according to machine and tooling conditions.

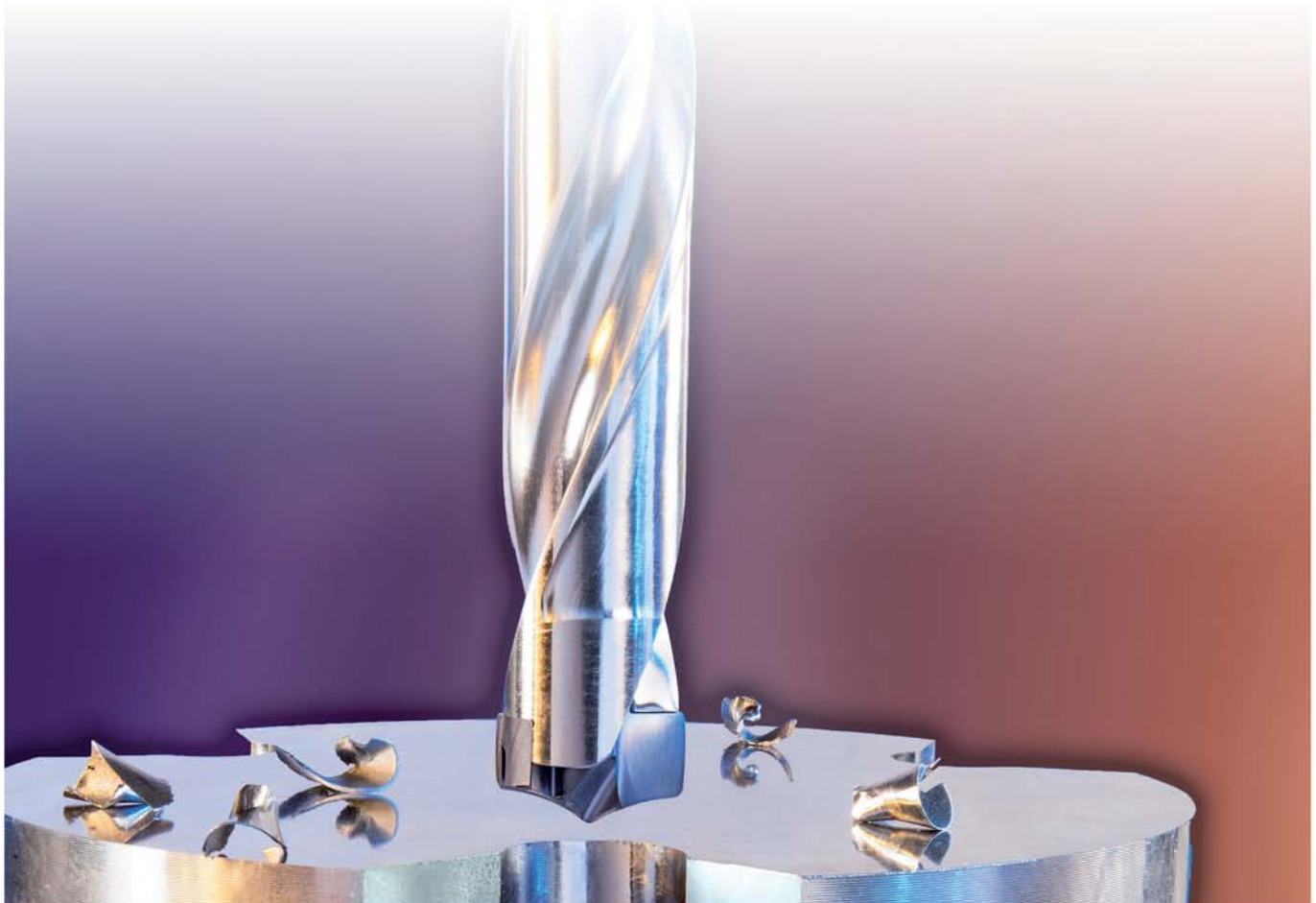

Drilling Heads for DHM Drills

Range 10-19.9

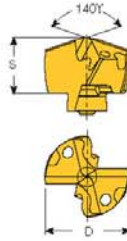

GHD (P/M/K/N)

Designation	D Range ⁽¹⁾	s	Pocket Size	DC9800
	10-10.9	7.0	10.0	●
	11-11.9	7.7	11.0	●
	12-12.9	7.8	12.0	●
GHDP □□□	13-13.9	8.4	13.0	●
GHDM □□□	14-14.9	8.8	14.0	●
GHDK □□□	15-15.9	9.2	15.0	●
GHDN □□□ ⁽²⁾	16-16.9	9.8	16.0	●
	17-17.9	9.8	17.0	●
	18-18.9	10.5	18.0	●
	19-19.9	10.8	19.0	●

⁽¹⁾ Heads are available in increments of 0.1 mm.

⁽²⁾ Available in DC208 only.

For 13.3 drill head: GHDP 133 DC 9800

Diameter Range 10.0-19.9 mm



■ ISO P
 ■ ISO M
 ■ ISO K
 ■ ISO N

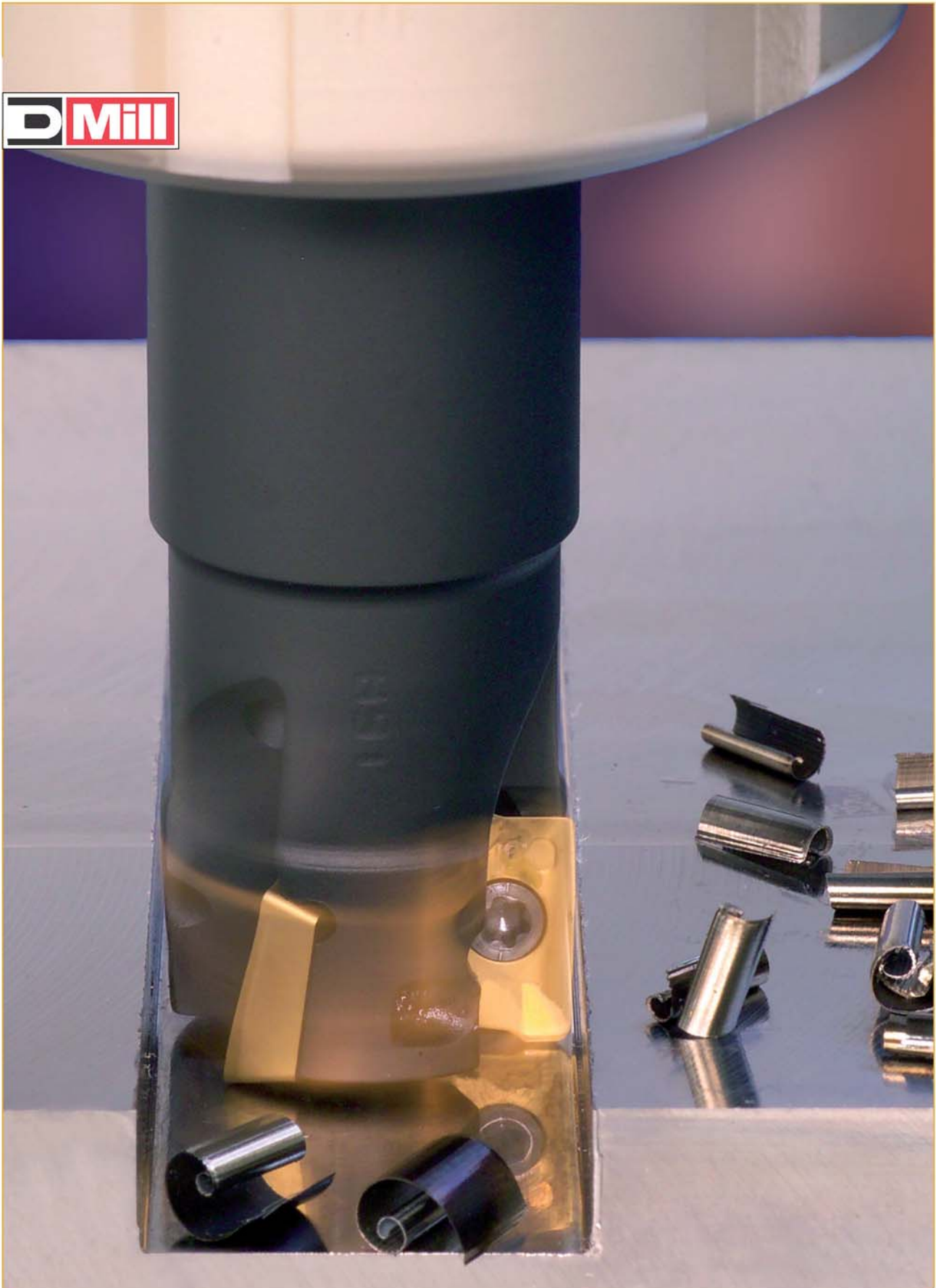

DMill

Designation System of Insert

1. Shape

2. Clearance Angle

3. Tolerance

Symbol	$\pm \Delta m$	$\pm \Delta s$	$\pm \Delta d$
A	0.005	0.025	0.025
C	0.013	0.025	0.025
E	0.025	0.025	0.025
K	0.013	0.025	0.05 d=9.525
			0.08 d=12.70
			0.10 d=15.87
M	0.07	0.13	0.05 d=9.525
			0.08 d=12.70
U	0.15	0.025	0.10 d=15.87
			0.013

5. Cutting Edge Length

6. Thickness

01t=1.59	05t=5.56
02t=2.38	06t=6.35
03t=3.18	07t=7.94
T3t=3.97	09t=9.52
04t=4.76	

A P K T 1 6 0 4 □ □ P D □ R

1 2 3 4 5 6 7 8 9 10

4. Type

7. Corner Radius

Symbol	Radius(mm)
04	0.4
08	0.8
16	1.6
24	2.4
32	3.2
48	4.8
64	6.35

8. Parallel Land

A=45°	C=7°
D=60°	P=11°
E=75°	D=15°
P=90°	E=20°
	F=25°

9. Edge Condition

10. Hand of Insert











Milling Program

Designation	Features•Application	Edge Geometry & Picture		Cutter Designation			
New GNMU 11, 16	• For steel, cast iron	M			•90° Endmill	90E...GN11/16	110
					•90° Facemill	90F...GN11/16	109
New SNMU 12	• For steel, cast iron	ANSN-M			•45° Facemill	45F...SN12	111
New ONMU ONHU	• For steel	TN-MM					
	• For cast iron	TN□/PL			•45° Facemill (wedge)	45FW...ON08	112
	• For general machining	N-HP			•45° Facemill (screw)	45FS...ON08	113
	• Wiper geometry	AN-N-W			•75° Facemill (screw)	75FF...ON08	114
APMT 16	• High positive geometry for lower cutting force	APMT-PDER			•90° Endmill	90E...AP16	136
					•90° Facemill	90F...AP16	137
APKT 08	• High positive geometry for lower cutting force	APKT-PDR			•90° Endmill	90E...08A	139
APKT 12	• High positive geometry for lower cutting force	APKT-PDR			•90° Endmill	90E...12A	138
OFCN 07 OFCR 07	• High feed & hardend steel	OFCN					
	• Stainless steel & low machine finish	OFCR			•43° Facemill	43F...OF07	140
	• Ground insert & good surface finish	OFCR-G					

Milling Program

Designation	Features•Application	Edge Geometry & Picture		Cutter Designation	
SDKN 12, 42 SDKN 15, 53	• For steel			• 45° Facemill	45F...SD12
	• For steel			• 45° Facemill	45F...SD15
SEKN 12 SEKN 15	• For steel			• 45° Facemill	45F...SE12
	• For steel			• 45° Facemill • 45° DM Facemill	45F...SE15 DMF45...SE12 DMF45...SE15 DMFN45...SE12
SPKN 12 SPKN 15	• General machining for cast iron			• 75° ISO Facemill	75F...SP12
	• For general machining			• 75° ISO Facemill • 75°(87.5°) DM Endmill	75F...SP15 DME75(87.5)...SP12
	• For general machining			• 75° DM Facemill	DMF75...SP15 DMF75...SP12 DMFN75...SP12 DMFN75...SP15
SNCN 12 SNKN 12 SNKR 12	• For general machining				
	• For general machining			• 45° Facemill • 75° Facemill	45F...SN12 75F...SN12
	• For general machining				

Milling Program

Designation	Features•Application	Edge Geometry & Picture		Cutter Designation	
TPKN 16/22	• General machining for cast iron			<ul style="list-style-type: none"> • 90° ISO Facemill • 90° DM Endmill 	90F...TP22 DME90...TP22 DME90...TP16
	• For general machining				
	• For general machining				
	• For general machining				
TEKN 22	• For general machining			<ul style="list-style-type: none"> • 90° DM Facemill 	DMFN90...TE22 DMF90...TE22

D2-Mill (90° Facemill)

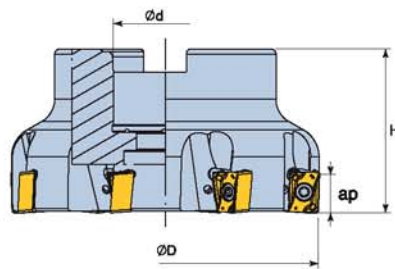
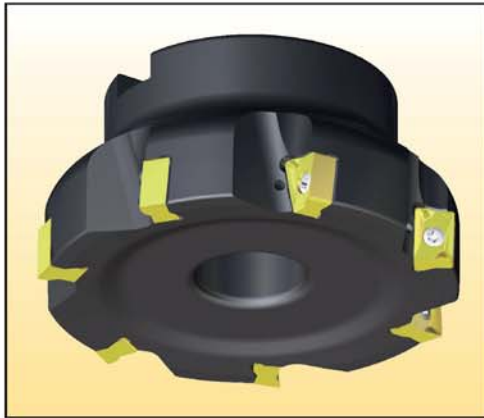

Fig.1

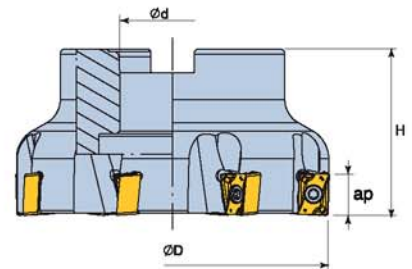
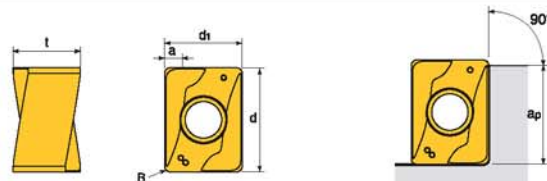

Fig.2

Designation	Insert		Dimension (mm)				Weight (Kg)		Fig.	Mounting Bolt
			D	d	H	ap				
90F4-D40-16R-GN11	GNMU 110605R-M	4	40	16	40	10	0.3	○	1	SH M8X1.25X25
90F5-D50-22R-GN11		5	50	22	40	10	0.4	○	1	SH M10X1.5X30
90F6-D63-22R-GN11		6	63	22	40	10	0.6	○	1	SH M10X1.5X30
90F8-D80-25.4R-GN11		8	80	25.4	50	10	1.1	○	1	SH M12X1.75X35
90F9-D100-31.75R-GN11		9	100	31.75	50	10	2.0	X	2	-
90F4-D50-22-GN16	GNMU 161008R-M	4	50	22	40	14.5	0.4	○	1	SH M10X1.5X30
90F4-D63-22-GN16		4	63	22	40	14.5	0.6	○	1	SH M10X1.5X30
90F7-D80-25.4-GN16		7	80	25.4	50	14.5	1.2	○	1	SH M12X1.75X35
90F8-D100-31.75-GN16		8	100	31.75	50	14.5	2.1	X	2	-

	Designation	Component		
		Screw	Wrench	
90F.....GN11	DS 30085I/HG-TS	DTDW-9	-	
90F.....GN16	DS 50B106I/HG-TS	-	DTTW-20	

GNMU 11, 16



Insert	Designation	Dimension (mm)						Cermet ^{New}					Coated		Uncoated	
		d	d ₁	t	R	a	ap	DC630	DP5320	DC9200	DC9235	DC9300	DC9800	DC210	DC325M	
	GNMU 110605R-M	11.00	7.10	6.6	0.50	1.20	10.0		●							
	GNMU 161008R-M	15.60	11.50	9.9	0.80	1.80	14.5		●							

D2-Mill (90° Endmill)

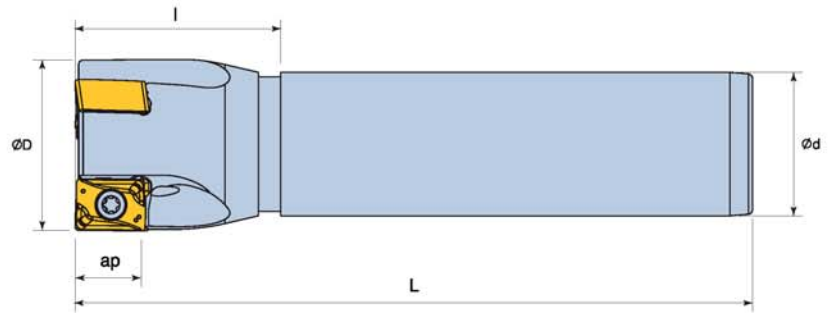

Designation	Insert		Dimension (mm)				
			D	d	L	l	ap
90E2-02020-GN11-L150	GNMU 110605R-M	2	20	20	150	40	10
90E3-02525-GN11-L150		3	25	25	150	40	10
90E4-03232-GN11-L150		4	32	32	150	40	10
90E2-03232-GN16-L150	GNMU 161008R-M	2	32	32	150	45	14.5
90E3-04032-GN16-L150		3	40	32	150	45	14.5

Designation	Component	
	Screw	Wrench
90E.....GN11	DS 30085I/HG-TS	DTDW-9
90E.....GN16	DS 50B106I/HG-TS	DTDW-20

GNMU 11, 16

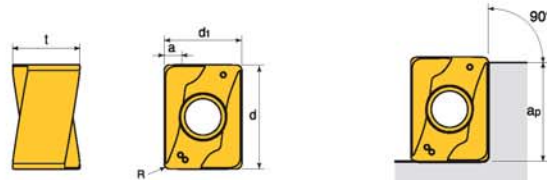

Insert	Designation	Dimension (mm)						Cermet	New	Coated				Uncoated		
		d	d1	t	R	a	ap			DC630	DP5320	DC9200	DC9235	DC9300	DC9800	DC210
	GNMU 110605R-M	11.00	7.10	6.6	0.50	1.20	10.0		•							
	GNMU 161008R-M	15.60	11.50	9.9	0.80	1.80	14.5		•							

D2-Mill (45° Facemill)

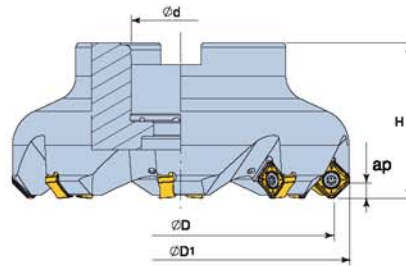

Fig.1

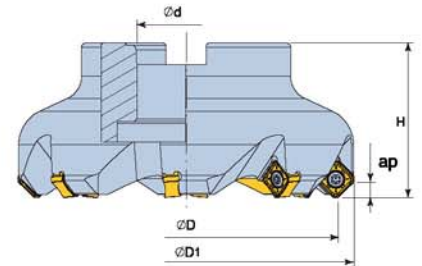
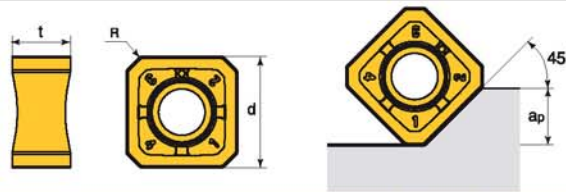

Fig.2

Designation	Insert		Dimension (mm)				Weight (Kg)		Fig.	Mounting Bolt
			D	d	H	ap				
45F4-D50-22R-SN12	SNMU 1206 ANSN-M	4	50	22	40	6	0.4	○	1	LH M10X1.5X25
45F5-D50-22R-SN12		5	50	22	40	6	0.4	○	1	LH M10X1.5X25
45F5-D63-22R-SN12		5	63	22	40	6	0.6	○	1	LH M10X1.5X25
45F6-D63-22R-SN12		6	63	22	40	6	0.6	○	1	LH M10X1.5X25
45F4-D80-25.4R-SN12		4	80	25.4	50	6	1.4	○	1	LH M12X1.75X30
45F7-D80-25.4R-SN12		7	80	25.4	50	6	1.4	○	1	LH M12X1.75X30
45F5-D100-31.75R-SN12		5	100	31.75	50	6	2.0	X	2	-
45F8-D100-31.75R-SN12		8	100	31.75	50	6	2.0	X	2	-
45F6-D125-38.1R-SN12		6	125	38.1	63	6	3.5	X	2	-
45F10-D125-38.1R-SN12		10	125	38.1	63	6	3.6	X	2	-

	Component	
	Screw	Wrench
	DS 40B100I-TS	DTTW-15

SNMU 12



Insert	Designation	Dimension (mm)					Coated					Uncoated		
		d	t	R	a	ap	DC630	DP5320	DC9200	DC9235	DC9300	DC9800	DC210	DC325M
	SNMU 1206 ANSN-M	12.00	6.3	0.40	2.1	6.0		●						

New

D2-Mill (45° Facemill)

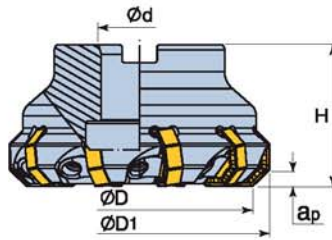

Fig.2

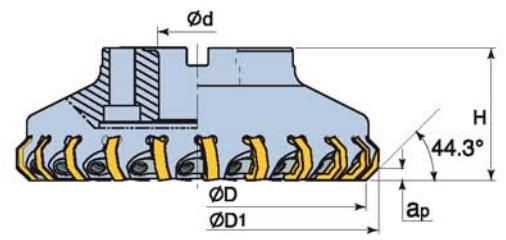
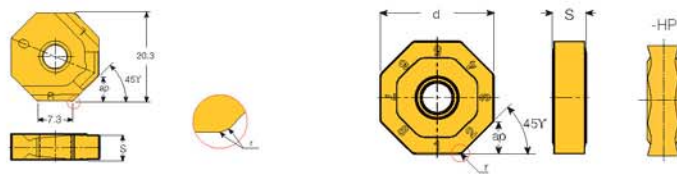

Fig.3

Designation	Insert		Dimension (mm)				Weight (Kg)	Fig.	
			D	D1	d	H			
45FW10 D80-27R-ON08	ONMU 080608-TN-MM ONHU 080608-TN-MM ONMU 080608-TN ONHU 080608-TN ONHU 0806AN-N-W		10	80	92	27	50	1.40	2
45FW14 D100-32R-ON08			14	100	112	32	63	2.10	2
45FW18 D125-40R-ON08			18	125	137	40	63	3.60	2
45FW22 D160-40R-ON08			22	160	172	40	63	5.30	3
45FW12 D200-60R-ON08			12	200	212	60	63	8.67	3
45FW28 D200-60R-ON08			28	200	212	60	63	8.50	3
45FW36 D250-60R-ON08			36	250	262	60	63	11.90	3
45FW44 D315-60R-ON08			44	315	327	60	80	20.00	3

	Component			
	Wedge	Screw	Wrench	Wrench
DLW 35-475/M	DSR 118-069	DBLD IP20/S7	DSW6-T	

ONMU/ONHU



Insert	Designation	Dimension (mm)					Grade							
		d	t	a	ap	r	DC9800	DC7610	DC9200	DC8236	DC9300	DC235	DC9235	
 New	ONMU 080608-TN	20.2	6	0.8	5.5	-		•	•					
	ONMU 080608-TN-MM	20.2	6	0.8	5.5	-	•			•		•	•	
	ONHU 080608-TN-MM	20.2	6	0.8	5.5	-	•				•	•	•	
	ONHU 080608-TN	20.2	6	0.8	5.5	-		•	•					
 New	ONHU 080600-N-PL	20.2	6		5.5	-			•					
	ONHU 080612-HL	20.2	6	1.2	5.5	-			•					
 New	ONHU 080608 AN-N-HP	20.2	6	0.8	2.5	-						•	•	
	ONHU 0806AN-N-W	20.4	6	-	5.5	0.4		•	•					

D2-Mill (45° Facemill)

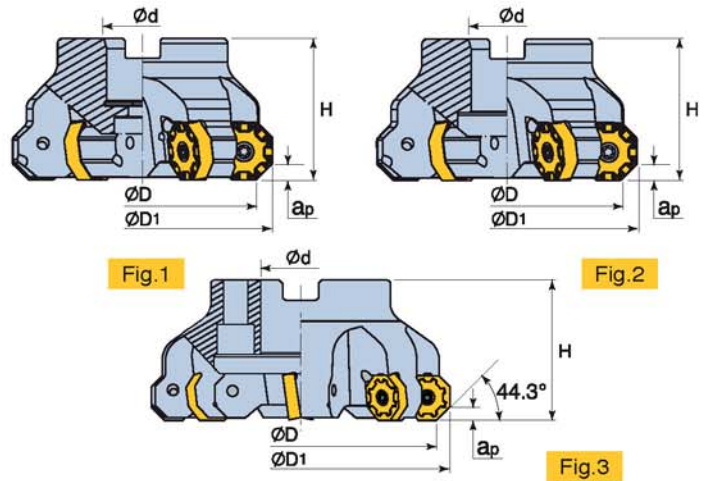
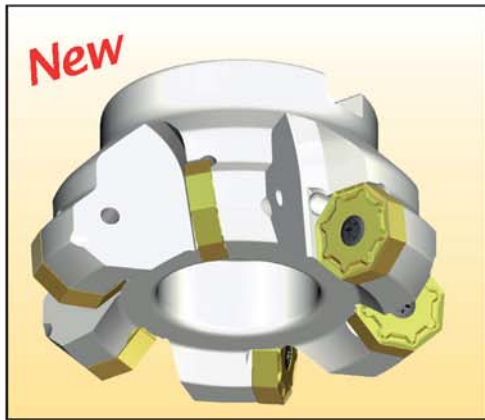

Designation	Insert		Dimension (mm)				Weight (Kg)	Fig.	Mounting Bolt
			D	D ₁	d	H			
45FS5 D63-22R-ON08	ONMU 080608-TN-MM ONMU 080608-TN ONHU 080608-TN	5	63	75.5	22	40	1.40	1	SR M10X25 DIN 912
45FS6 D80-27R-ON08		6	80	92.5	27	50	2.10	2	-
45FS7 D100-32R-ON08		7	100	112.5	32	60	3.60	2	-
45FS8 D125-40R-ON08		8	125	137.5	40	63	5.30	2	-
45FS10 D160-40R-ON08		10	160	172.5	40	63	8.67	3	-
45FS12 D200-60R-ON08		12	200	212.5	60	63	8.50	3	-
45FS14 D250-60R-ON08		14	250	262.5	60	63	11.90	3	-
45FS16 D315-60R-ON08		16	315	324.5	60	80	20.00	3	-

	Component		
	Screw	Wrench	Wrench
DSR 14-591/H	DBLD T20/S7	DSW6-T	

ONMU/ONHU

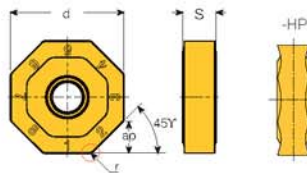

Insert	Designation	Dimension (mm)				Grade						
		d	t	a	ap	DC9800	DC7610	DC9200	DC8236	DC9300	DC235	DC9235
	ONMU 080608-TN	20.2	6	0.8	5.5		•	•				
	ONMU 080608-TN-MM	20.2	6	0.8	5.5	•			•		•	•
	ONHU 080608-TN	20.2	6	0.8	5.5		•	•				

D2-Mill (High Feed Facemill)

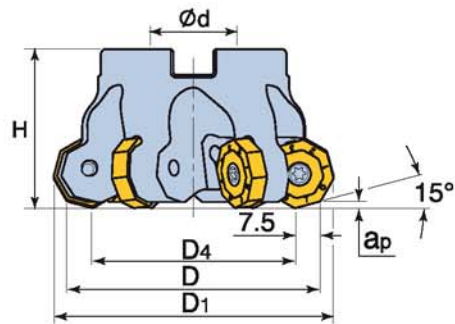

Designation	Insert		Dimension (mm)				
			D	D ₁	D ₂	H	A _p max
75FF6 D80-27R-ON08	ONMU 080612-HL ONMU 080608-TN-MM	6	80	88	64.5	50	2

	Component		
	Screw	Wrench	Wrench
	DSR 14-591/H	DBLD T20/S7	DSW6-T

ONMU/ONHU

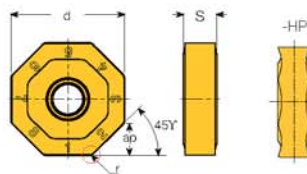

Insert	Designation	Dimension (mm)				Grade						
		d	t	a	a _p	DC9800	DC7610	DC9200	DC8236	DC9300	DC235	DC9235
 New	ONMU 080608-TN-MM	20.2	6	0.8	5.5	•			•		•	•
 New	ONHU 080612-HL	20.2	6	1.2	5.5			•				

90° Endmill

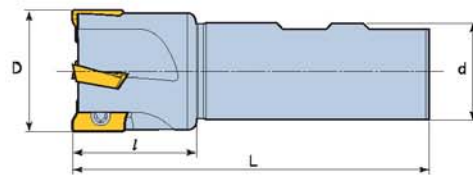

Fig.1

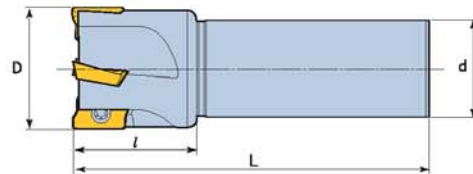
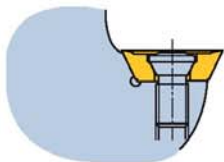

Fig.2

Designation	Insert		Dimension (mm)				Fig.
			D	d	L	l	
90E02525W-AP16-L100	APMT 1604 PDER	2	25	25	100	39	1
90E02525-AP16-L210		2	25	25	210	40	2
90E02625-AP16-L200		2	26	25	200	40	2
90E02625-AP16-L250		2	26	25	250	40	2
90E03232WF-AP16-L110		3	32	32	110	33	1
90E03232-AP16-L250		2	32	32	250	65	2
90E03332-AP16-L250		2	33	32	250	40	2
90E03332F-AP16-L250		3	33	32	250	55	2
90E03332-AP16-L300		2	33	32	300	40	2
90E03232W-AP16-L200		3	32	32	200	65	1
90E04032-AP16-L250		2	40	32	250	54	2
90E04032F-AP16-L200		3	40	32	200	54	2



Component	
Screw	Wrench
*DS40080I-TS, DS40120I-TS	DTTW-15

* DS40080W-TS: For Ø25 cutter

APMT 1604 PDER

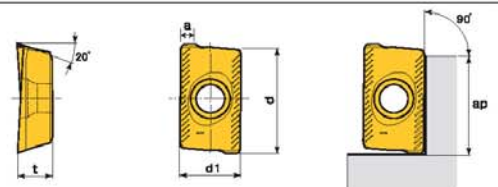

Insert	Designation	Dimension (mm)						Coated						Uncoated					
		d	d1	a	t	R	ap	DC9200	DP7320	DC9235	DP8330	DC9300	DP9320	DC9800	DP5320	DC7800	DC210	DC325M	
	APMT 1604 PDER	16.4	9.45	1.7	5.25	0.8	13	•		•		•		•					

90° Facemill

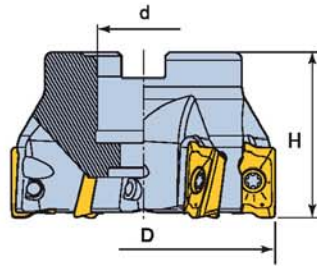
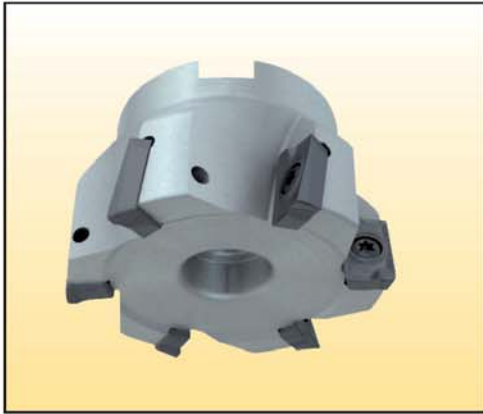

Fig.1

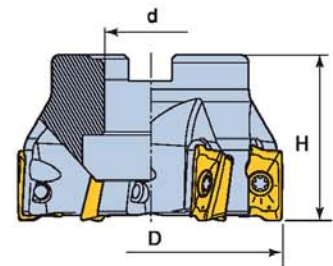
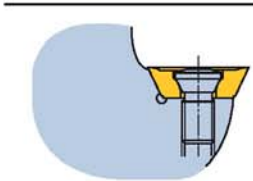

Fig.2

Designation	Insert		Dimension (mm)			Fig.	Mounting Bolt
			D	d	H		
90F-D50-22-AP16	APMT 1604 PDER	3	50	22	40	1	SH M10 X 1.5 X 30
90F-D63-22-AP16		4	63	22	40	1	SH M10 X 1.5 X 30
90F-D80-27-AP16		5	80	27	50	1	SH M12 X 1.75 X 35
90F-D100-32-AP16		6	100	32	50	2	-



Component	
Screw	Wrench
*DS40093I-TS, DS40120I-TS	DTTW-15

* DS40093W-TS: For Ø50-Ø63 cutter

APMT 1604 PDER

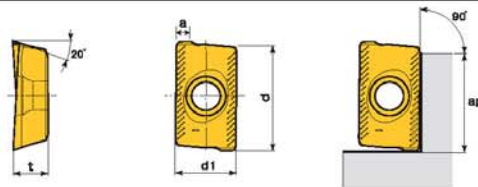

Insert	Designation	Dimension (mm)						Coated							Uncoated				
		d	d1	a	t	R	ap	DC9200	DP7320	DC9235	DP8330	DC9300	DP9320	DC9800	DP5320	DC7800	DC210	DC325M	
	APMT 1604 PDER	16.4	9.45	1.7	5.25	0.8	13	•		•		•		•					

90° Endmill - APKT 1203

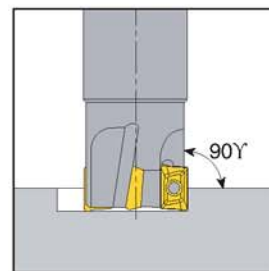
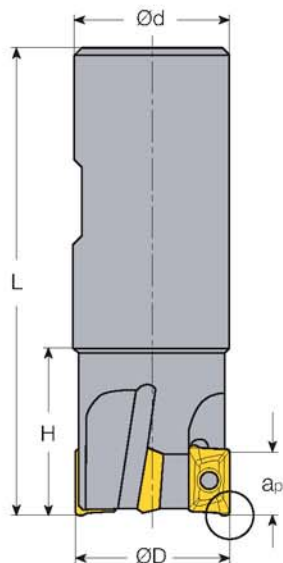

Cutting angles
 Lead angle 90°
 Axial rake 3°
 $+13^\circ$
 Radial rake 20°

Designation	Insert		Dimension (mm)				ap
			D	d	H	L	
90E01216S-12A	APKT 1203	1	12	16	20	75	12
90E01616S-12A		1	16	16	25	85	12
90E02020S-12A		2	20	20	28	90	12
90E02525S-12A		3	25	25	32	100	12
90E03232S-12A		4	32	32	30	110	12

	Component	
	Screw	Wrench
	SM30-065-00	DTTW09

APKT...1203

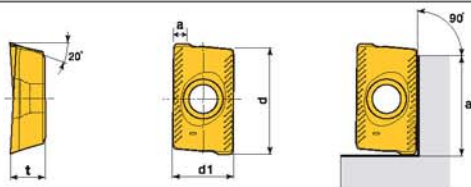

Insert	Designation	Dimension (mm)				Coated			Uncoated
		d	d1	t	R	DC9235	DC9800	DC9200	DC3254
	APKT 1203PDR	12.2	8	3.8	0.8	•	•	•	•
	APKT 120316R	12.2	8	3.8	1.6	•		•	•
	APKT 120332R	12.2	8	3.8	3.2	•		•	•
	APKT 120364R	12.2	8	3.8	6.4	•			•

90° Endmill - APKT 0803

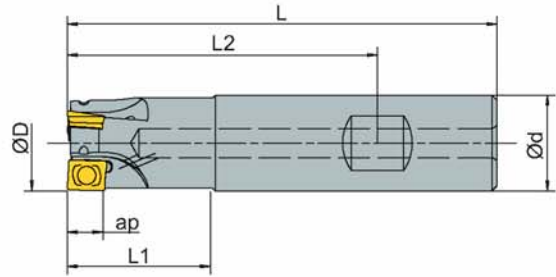

Designation	Insert		Dimension (mm)							Weight (Kg)	
			D	d	L	L1	L2	ap			
90E010 16W-08A	APKT 0803		1	10	16	80	18	56	7.5	✓	0.08
90E012 16W-08A			1	12	16	80	20	56	7.5	✓	0.09
90E016 16W-08A			2	16	16	85	26	61	7.5	✓	0.10
90E020 20W-08A			3	20	20	90	30	65	7.5	✓	0.18
90E025 25W-08A			4	25	25	100	40	68	7.5	✓	0.32
90E032 32W-08A			4	32	32	155	93	119	7.5	✓	0.85

	Component	
	Screw	Wrench
	SM25-054-00	DS-T08S
	SM25-064-00	DS-T08S

For D10-D12 SM25-054-00

For D16-D32 SM25-064-00

APKT...0803

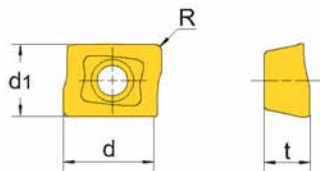

Insert	Designation	Dimension (mm)				Coated				
		d	d1	t	R	DC235	DC9235	DC150	DC9800	DC9200
	APKT 080304R	7.9	6.2	3.45	0.4		•	•	•	•
	APCR 080304R	7.9	6.2	3.45	0.4		•			
	APCR 080304R-P	7.9	6.2	3.45	0.4	•				

43° Facemill

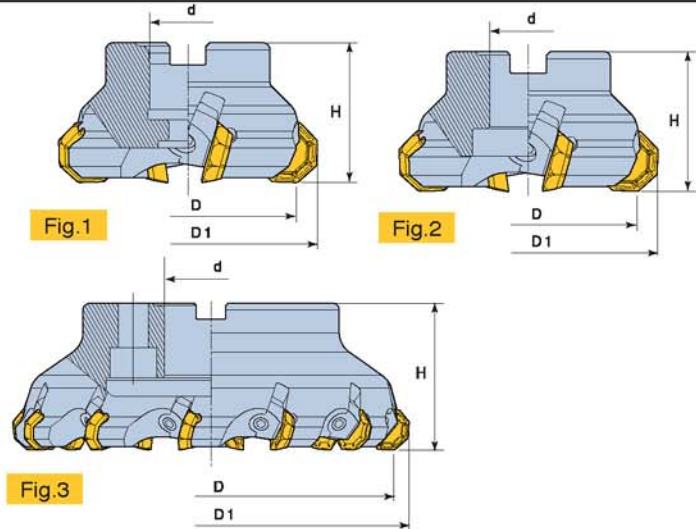

Designation	Insert		Dimension (mm)				Weight (Kg)	Fig.	Mounting Bolt	
			D	D1	d	H				
43F-D63-22-OF07	OFCN 0704 OFCR 0704-G		4	63	75.4	22	40	0.5	1	SH M10 X 1.5 X 30
43F-D80-27-OF07			5	80	92.3	27	50	1.2	1	SH M12 X 1.75 X 35
43F-D100-32-OF07			6	100	112.3	32	50	1.8	2	-
43F-D125-40-OF07			8	125	137.7	40	63	3	2	-
43F-D160-40-OF07			10	160	172.3	40	63	4.7	3	-
43F-D200-60-OF07			12	200	212.3	60	63	7	3	-
43F-D80-25.4-OF07			5	80	92.3	25.4	50	1.2	1	SH M12 X 1.75 X 35
43F-D100-31.75-OF07			6	100	112.3	31.75	50	1.8	2	-
43F-D125-38.1-OF07			8	125	137.7	38.1	63	3	2	-
43F-D160-50.8-OF07			10	160	172.3	50.8	63	4.7	3	-

	Component		
	Wedge	Screw	Wrench
DWFO-8Z	DWS8S	DTTW-4	

OFCN 07 & OFCR 07

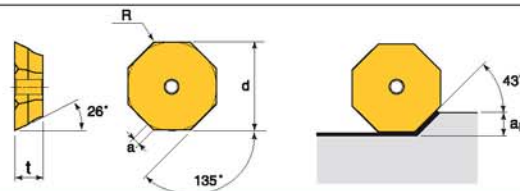

Insert	Designation	Dimension (mm)					Coated								Uncoated		
		d	t	a	R	ap	DC9200	DP7320	DC9235	DP8330	DC9300	DP9320	DC9800	DP5320	DC7800	DC210	DC325M
	OFCN 0704	17.94	5.1	1.7	0.8	5	•				•						
	OFCR 0704-G	17.94	5.1	1.7	0.8	5	•				•						

45° ISO Facemill (ISO Insert)

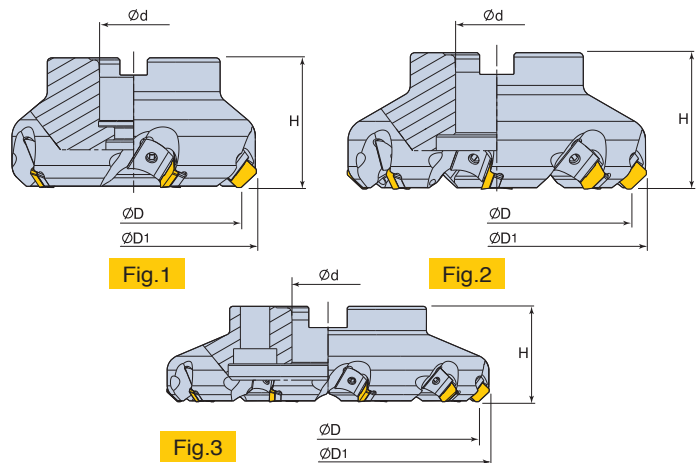
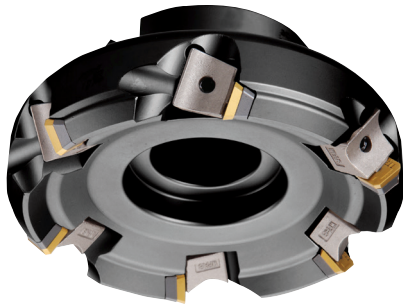

Designation	Insert		Dimension(mm)				Weight (Kg)	Fig.	Mounting Bolt	
			D	D ₁	d	H				
45F-D80-25.4-SD12	SDKN 1203 MT-HPN SDKN 42 MT-GPN		4	80	93.8	25.4	50	1.6	1	LH M12 X 1.75 X 30
45F-D100-31.75-SD12			5	100	113.8	31.75	60	2.8	1	LH M16 X 2 X 35
45F-D125-38.1-SD12			6	125	138.8	38.1	63	3.5	2	-
45F-D160-50.8-SD12			8	160	173.9	50.8	63	5.5	2	-
45F-D200-47.625-SD12			10	200	213.9	47.625	63	7.6	3	-
45F-D250-47.625-SD12			12	250	263.9	47.625	63	12.6	3	-

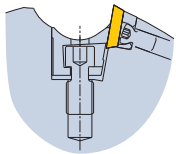

Component				
Shim	Wedge	Shim Screw	Wedge Screw	Wrench
DSSDSE 12N	DWPA 8	DS 40B100I-TS	DS 80200W-TS	DTTW-4

SDKN 12

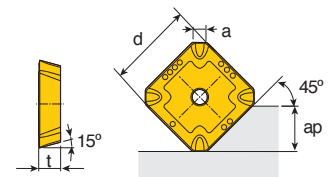

Insert	Designation	Dimension(mm)				Coated					Uncoated	
		d	t	a	ap	DP5320	DP7320	DP9320	DC7800	DC9235	DC210	DC325M
	SDKN 1203 MT-HPN	12.7	3.18	2.0	6.4			•				
	SDKN 42 MT-GPN	12.7	3.18	2.0	6.4			•		•		•

45° ISO Facemill (ISO Insert)

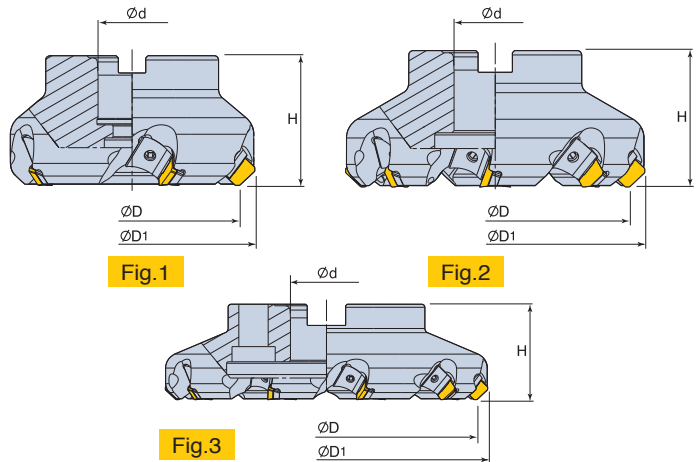
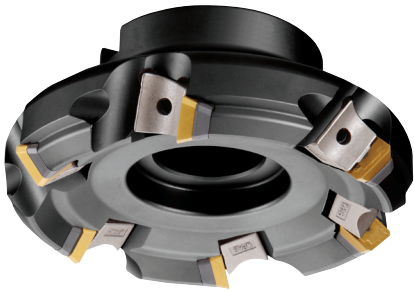

Designation	Insert		Dimension(mm)				Weight (Kg)	Fig.	Mounting Bolt	
			D	D1	d	H				
45F-D80-25.4-SD15	SDKN 1504 MT-HPN SDKN 53 MT-HPN SDKN 53 MT-GPN		4	80	98.3	25.4	50	1.6	1	LH M12 X 1.75 X 30
45F-D100-31.75-SD15			5	100	118.6	31.75	60	2.8	1	LH M16 X 2 X 35
45F-D125-38.1-SD15			6	125	143.6	38.1	63	3.5	2	-
45F-D160-50.8-SD15			8	160	178.6	50.8	63	5.5	2	-
45F-D200-47.625-SD15			10	200	218.6	47.625	63	7.6	3	-
45F-D250-47.625-SD15			12	250	268.6	47.625	63	12.6	3	-

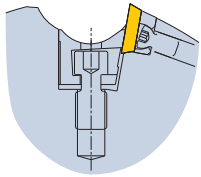

Component				
Shim	Wedge	Shim Screw	Wedge Screw	Wrench
DSSDSE 15N	DWPA 8	DS 40B100I-TS	DS 80200W-TS	DTTW-4

SDKN 15

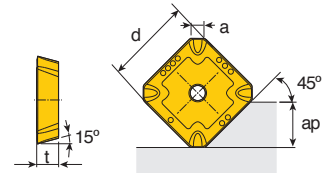

Insert	Designation	Dimension(mm)				Coated					Uncoated	
		d	t	a	ap	DP5320	DP7320	DP9320	DC7800	DC9235	DC210	DC325M
	SDKN 1504 MT-HPN	15.875	4.76	1.89	8.5			•				
	SDKN 53 MT-HPN	15.875	4.76	1.89	8.5			•				
	SDKN 53 MT-GPN	15.875	4.76	1.89	8.5		•	•		•		•

45° ISO Facemill (ISO Insert)

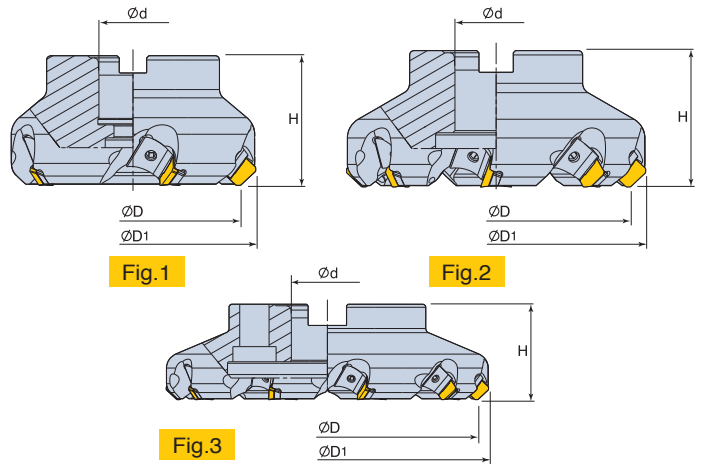

Designation	Insert		Dimension(mm)				Weight (Kg)	Fig.	Mounting Bolt	
			D	D1	d	H				
45F-D80-25.4-SE12	SEKN 1203 AFSN-GPN SEKN 1203 AFSN-HPN		4	80	93.7	25.4	55	1.5	1	LH M12 X 1.75 X 30
45F-D100-31.75-SE12			5	100	113.6	31.75	60	2.4	1	LH M16 X 2 X 35
45F-D125-38.1-SE12			6	125	138.6	38.1	63	2.7	2	-
45F-D160-50.8-SE12			8	160	173.6	50.8	63	4.2	2	-
45F-D200-47.625-SE12			10	200	213.5	47.625	63	6.1	3	-
45F-D250-47.625-SE12			12	250	263.5	47.625	63	11.1	3	-
45F-D315-47.625-SE12			14	315	328.5	47.625	63	17.5	3	-

	Component				
	Shim	Wedge	Shim Screw	Wedge Screw	Wrench
DSSDSE 12N	DWPA 8	DS 40B100I-TS	DS 80200W-TS	DTTW-4	

SEKN 12

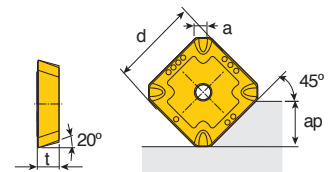

Insert	Designation	Dimension(mm)				Coated					Uncoated	
		d	t	a	ap	DP5320	DP7320	DP9320	DC7800	DC9235	DC210	DC325M
	SEKN 1203 AFSN-HPN	12.7	3.18	2.0	6.4			•				
	SEKN 1203 AFSN-GPN	12.7	3.18	2.08	6.4		•	•		•		•

45° ISO Facemill (ISO Insert)

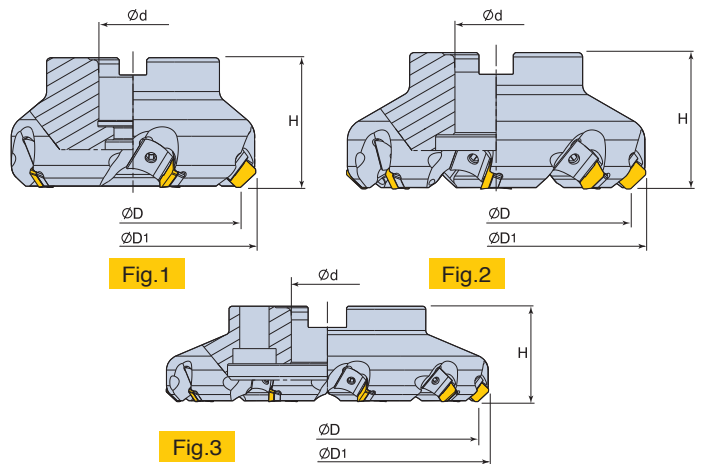

Designation	Insert		Dimension(mm)				Weight (Kg)	Fig.	Mounting Bolt	
			D	D1	d	H				
45F-D80-25.4-SE15	SEKN 1504 AFSN-GPN SEKN 1504 AFSN-HPN		4	80	93.7	25.4	55	1.5	1	LH M12 X 1.75 X 30
45F-D100-31.75-SE15			5	100	113.6	31.75	60	2.4	1	LH M16 X 2 X 35
45F-D125-38.1-SE15			6	125	138.6	38.1	63	2.7	2	-
45F-D160-50.8-SE15			8	160	173.6	50.8	63	4.2	2	-
45F-D200-47.625-SE15			10	200	213.5	47.625	63	6.1	3	-
45F-D250-47.625-SE15			12	250	263.5	47.625	63	11.1	3	-

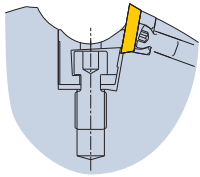

Component				
Shim	Wedge	Shim Screw	Wedge Screw	Wrench
DSSDSE 15N	DWPA 8	DS 40B100I-TS	DS 80200W-TS	DTTW-4

SEKN 15

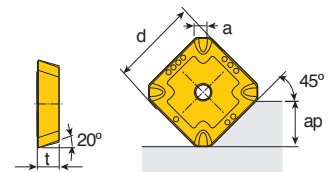

Insert	Designation	Dimension(mm)				Coated					Uncoated	
		d	t	a	ap	DP5320	DP7320	DP9320	DC7800	DC9235	DC210	DC325M
	SEKN 1504 AFSN-HPN	15.875	4.76	1.89	8.5		•	•		•		
	SEKN 1504 AFSN-GPN	15.875	4.76	2.06	8.5		•	•		•		•

45° Facemill

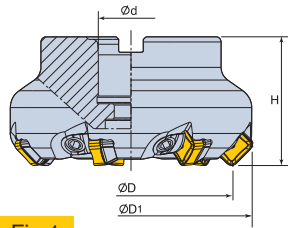
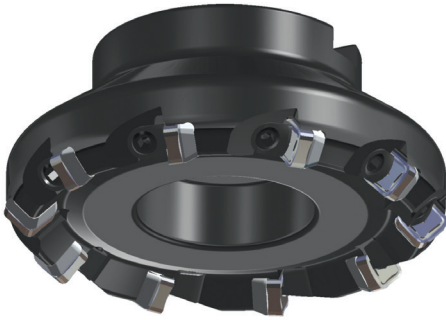

Fig.1

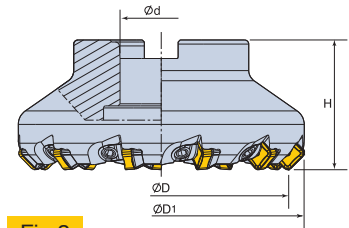

Fig.2

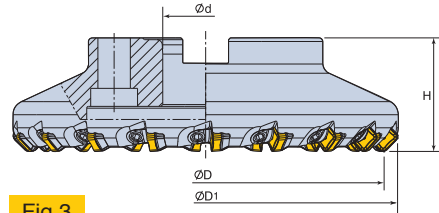
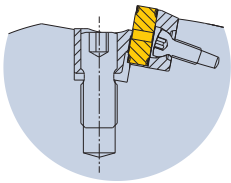

Fig.3

Designation	Insert		Dimension(mm)				Weight (Kg)	Fig.	Mounting Bolt
			D	D ₁	d	H			
45F-D80-25.4-SN12	SNCN 1204 EN SNKN 1204 EN-EM+ SNKR 1204 XTN-EM	6	80	95	25.4	50	1.7	1	LH M12X1.75X30
45F-D100-31.75-SN12		8	100	115	31.75	50	2.2	2	-
45F-D125-38.1-SN12		10	125	140	38.1	63	3.7	2	-
45F-D160-50.8-SN12		14	160	175	50.8	63	5.6	2	-
45F-D200-47.625-SN12		18	200	215	47.625	63	7.5	3	-
45F-D250-47.625-SN12		22	250	265	47.625	63	10.9	3	-



Component				
Shim	Wedge	Shim Screw	Wedge Screw	Wrench
DTSSN 12N	DWFZ 8H-SN	DS 40B100I-TS	DWS 8	DTTW-4

SNCN 12 & SNKN 12 & SNKR 12

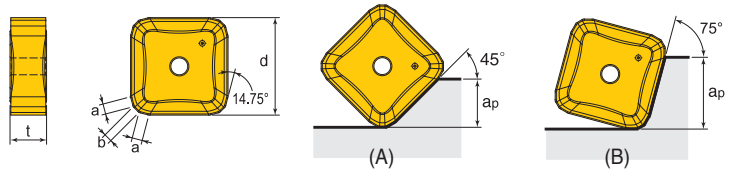

Insert	Designation	Dimension(mm)						Coated					Uncoated		
		d	t	a	b	ap(A)	ap(B)	DP5320	DP7320	DP9320	DC7800	DC9235	DC210	DC325M	
	SNCN 1204 EN	12.7	4.76	1.50	0.9	-	-		•						•
	SNKN 1204 EN-EM+	12.7	4.76	1.34	1.06	6.2	9.3		•	•					•
	SNKR 1204 XTN-EM	12.7	4.76	1.34	1.06	6.2	9.3	•	•	•					

Coating Hole: Coated(O), Uncoated (X)

75° Facemill

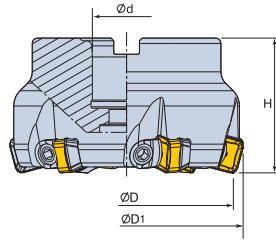
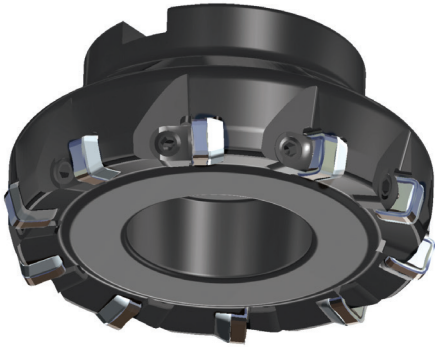

Fig.1

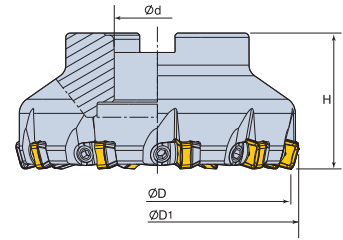

Fig.2

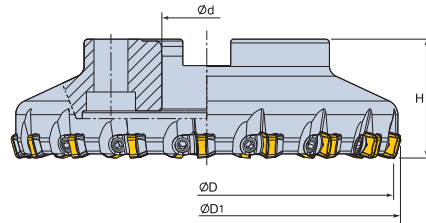
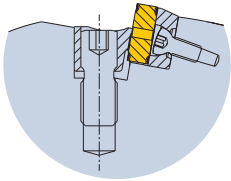

Fig.3

Designation	Insert		Dimension(mm)				Weight (Kg)	Fig.	Mounting Bolt
			D	D ₁	d	H			
75F-D80-25.4-SN12	SNCN 1204 EN SNKN 1204 EN-EM+ SNKR 1204 XTN-EM	5	80	87.4	25.4	50	1.6	1	SH M12X1.75X35
75F-D100-31.75-SN12		8	100	107.4	31.75	50	2.1	2	-
75F-D125-38.1-SN12		10	125	132.4	38.1	63	3.6	2	-
75F-D160-50.8-SN12		14	160	167.4	50.8	63	5	2	-
75F-D200-47.625-SN12		18	200	207.4	47.625	63	7.5	3	-
75F-D250-47.625-SN12		22	250	257.4	47.625	63	10.9	3	-



Component				
Shim	Wedge	Shim Screw	Wedge Screw	Wrench
DSSP 12N	DWFZ 8H-SN	DS 40B100I-TS	DWS 8	DTTW-4

SNCN 12 & SNKN 12 & SNKR 12

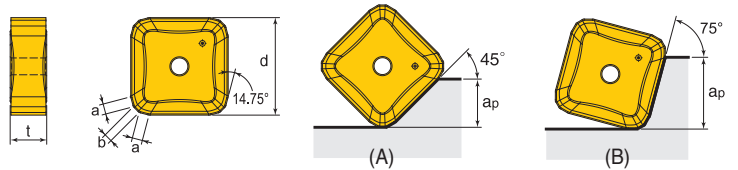

Insert	Designation	Dimension(mm)						Coated					Uncoated		
		d	t	a	b	ap(A)	ap(B)	DP5320	DP7320	DP9320	DC7800	DC9235	DC210	DC325M	
	SNCN 1204 EN	12.7	4.76	1.50	0.9	-	-		•						•
	SNKN 1204 EN-EM+	12.7	4.76	1.34	1.06	6.2	9.3		•	•					•
	SNKR 1204 XTN-EM	12.7	4.76	1.34	1.06	6.2	9.3	•	•	•					

Coating Hole: Coated(O), Uncoated (X)

75° ISO Facemill (ISO Insert)

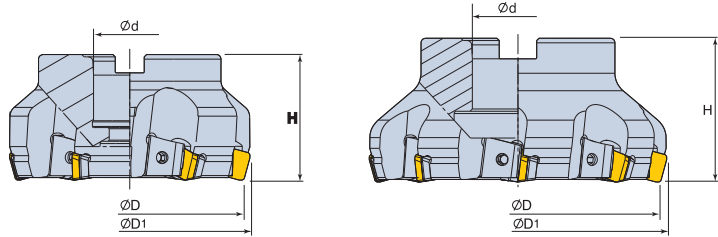

Fig.1

Fig.2

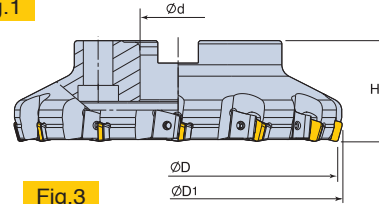
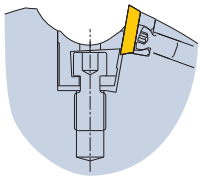

Fig.3

Designation	Insert		Dimension(mm)				Weight (Kg)	Fig.	Mounting Bolt	
			D	D ₁	d	H				
75F-D80-25.4-SP12	SPKN 1203 EDR-HPN SPKN 1203 EDSR-HPN SPKN 1203 EDSR-GPN		5	80	85.4	25.4	50	1.2	1	SH M12 X 1.75 X 35
75F-D100-31.75-SP12			5	100	105.4	31.75	55	1.8	1	LH M16 X 2 X 35
75F-D125-38.1-SP12			8	125	130.4	38.1	63	2.8	2	-
75F-D160-50.8-SP12			10	160	165.4	50.8	63	4.8	2	-
75F-D200-47.625-SP12			12	200	205.4	47.625	63	6.4	3	-
75F-D250-47.625-SP12			16	250	255.4	47.625	63	11.1	3	-
75F-D315-47.625-SP12			20	315	320.4	47.625	63	17.3	3	-



Component				
Shim	Wedge	Shim Screw	Wedge Screw	Wrench
DSSP 12N	DWPA 8	DS 40B100I-TS	DS 80200W-TS, *DS 80160W-TS	DTTW-4

* DS 80160W-TS: For $\varnothing 80$ cutter

SPKN 12

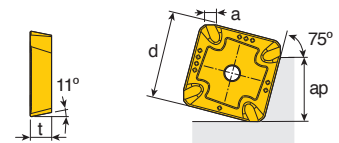

Insert	Designation	Dimension(mm)				Coated					Uncoated	
		d	t	a	ap	DP5320	DP7320	DP9320	DC7800	DC9235	DC210	DC325M
	SPKN 1203 EDR-HPN	12.7	3.18	1.6	8		•					•
	SPKN 1203 EDSR-HPN	12.7	3.18	1.2	8			•		•		
	SPKN 1203 EDSR-GPN	12.7	3.18	1.3	8			•				•

75° ISO Facemill (ISO Insert)

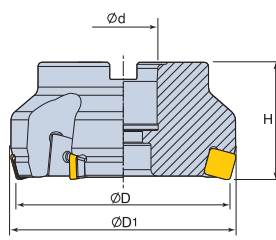

Fig.1

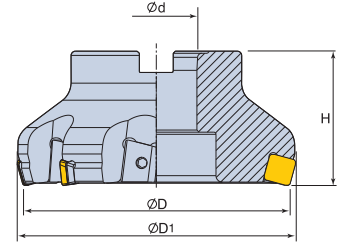

Fig.2

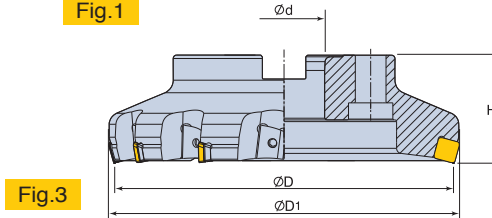
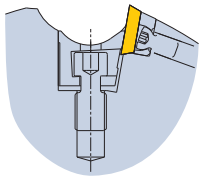

Fig.3

Designation	Insert		Dimension(mm)				Weight (Kg)	Fig.	Mounting Bolt	
			D	D ₁	d	H				
75F-D80-25.4-SP15	SPKN 1504 EDR-HPN SPKN 1504 EDSR-HPN SPKN 1504 EDSR-GPN		5	80	87.0	25.4	55	1.3	1	SH M12 X 1.75 X 35
75F-D100-31.75-SP15			5	100	107.0	31.75	55	2.0	1	LH M16 X 2 X 35
75F-D125-38.1-SP15			8	125	132.0	38.1	63	2.7	2	-
75F-D160-50.8-SP15			10	160	166.9	50.8	63	4.7	2	-
75F-D200-47.625-SP15			12	200	206.9	47.625	63	6.4	3	-
75F-D250-47.625-SP15			16	250	256.9	47.625	63	10.8	3	-
75F-D315-47.625-SP15			20	315	321.9	47.625	63	17.9	3	-



Component				
Shim	Wedge	Shim Screw	Wedge Screw	Wrench
DSSP 15N	DWPA 8	DS 40B100I-TS	DS 80200W-TS, *DS 80160W-TS	DTTW-4

* DS 80160W-TS: For Ø80 cutter

SPKN 15

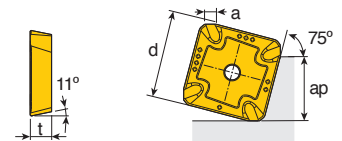

Insert	Designation	Dimension(mm)				Coated						Uncoated	
		d	t	a	ap	DP5320	DP7320	DP9320	DC7800	DC9235	DC9300	DC210	DC325M
	SPKN 1504 EDR-HPN	15.875	4.76	1.6	12	•	•			•			•
	SPKN 1504 EDSR-HPN	15.875	4.76	1.4	12			•					
	SPKN 1504 EDSR-GPN	15.875	4.76	1.5	12		•	•					•

90° ISO Facemill (ISO Insert)

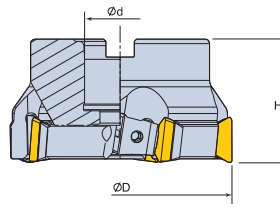

Fig.1

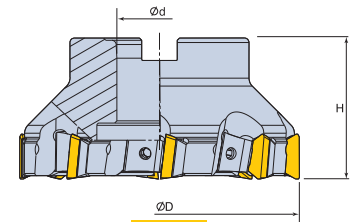

Fig.2

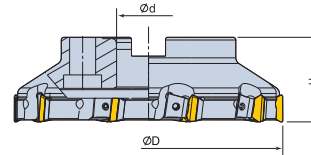
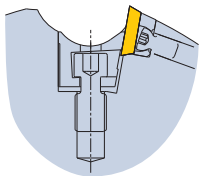

Fig.3

Designation	Insert		Dimension(mm)			Weight (Kg)	Fig.	Mounting Bolt
			D	d	H			
90F-D80-25.4-TP22	TPKN 2204 PDR-HPN TPKN 2204 PDSR-HPN TPKN 2204 PDSR-GPN	4	80	25.4	50	0.9	1	SH M12 X 1.75 X 35
90F-D100-31.75-TP22		5	100	31.75	55	1.8	1	LH M16 X 2 X 35
90F-D125-38.1-TP22		6	125	38.1	63	2.6	2	-
90F-D160-50.8-TP22		8	160	50.8	63	4.3	2	-
90F-D200-47.625-TP22		10	200	47.625	63	5.9	3	-
90F-D250-47.625-TP22		12	250	47.625	63	10.5	3	-
90F-D315-47.625-TP22		14	315	47.625	63	16.7	3	-



Component				
Shim	Wedge	Shim Screw	Wedge Screw	Wrench
DSTP 22N	DWPA 8	DS 40B100I-TS	DS 80200W-TS, *DS 80160W-TS	DTTW-4

* DS 80160W-TS: For Ø80 cutter

TPKN 22

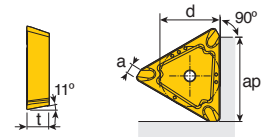

Insert	Designation	Dimension(mm)				Coated					Uncoated	
		d	t	a	ap	DP5320	DP7320	DP9320	DC7800	DC9235	DC210	DC325M
	TPKN 2204 PDR-HPN	12.7	4.76	1.7	16		•			•		•
	TPKN 2204 PDSR-HPN	12.7	4.76	1.41	16			•		•		
	TPKN 2204 PDSR-GPN	12.7	4.76	1.5	16			•				

45° ISO Facemill (ISO Insert)

Type 1 (Wedge + Shim Clamp)

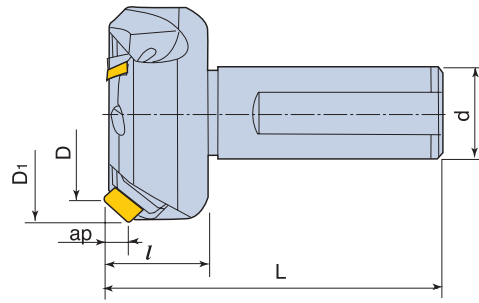

Designation	Insert		Dimension(mm)					
			D	D1	d	L	l	ap
DMFN45-D63-SE12	SEKN 1203 AFSN-HPN SEKN 1203 AFSN-GPN	3	63	76.5	32	115	35	6

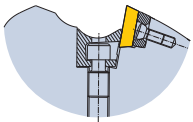

Shim	Wedge	Shim Screw	Wedge Screw	Wrench	Shim Screw Wrench
DSSDSE 12N	DWPA 8	DS 40B100I-TS	DS 80200W-TS	DTTW-4	DTTW-15 ⁽¹⁾

• DTTW-15⁽¹⁾ is not included in the package

Type 2 (Wedge)

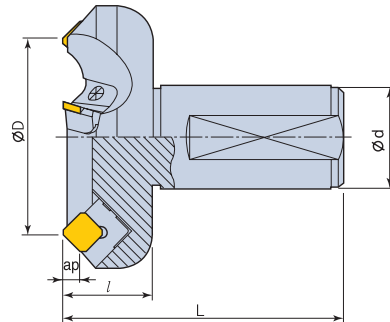

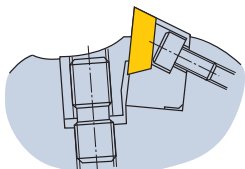

Designation	Insert		Dimension(mm)				
			D	d	L	l	ap
DMF45-D63-SE12	SEKN 1203 AFSN-HPN SEKN 1203 AFSN-GPN	3	63	32	115	35	4
DMF45-D63-SE15	SEKN 1504 AFSN-HPN SEKN 1504 AFSN-GPN	3	63	32	115	35	5
DMF45-D80-SE15		4	80	42	115	37	5

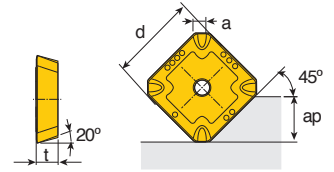

Designation	Component				
	Anvil	Wedge	Anvil Screw	Wedge Screw	Wrench
DMF45...SE12	DASE54R	DWSE54R	SH M4 X 0.7 X 8	DWS8	DTTW-4
DMF45...SE15	DASE55R				

SEKN 12/15

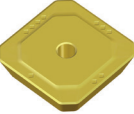

Insert	Designation	Dimension(mm)						Coated					Uncoated	
		d	t	a	ap			DP5320	DP7320	DP9320	DC7800	DC9235	DC210	DC325M
	SEKN 1203 AFSN-HPN	12.7	3.18	2.0	6.4					•				
	SEKN 1504 AFSN-HPN	15.875	4.76	1.89	8.5				•	•		•		
	SEKN 1203 AFSN-GPN	12.7	3.18	2.08	6.4				•	•		•		•
	SEKN 1504 AFSN-GPN	15.875	4.76	2.06	8.5				•	•		•		•

75° (87.5°) DM Endmill (ISO Insert)

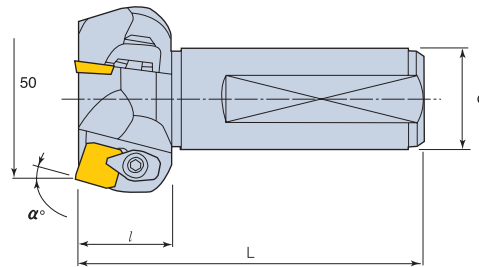

Designation	Insert		Dimension(mm)					
			α°	d	L	l	ap	d
DME87.5-D50-SP12	SPGN 120308	3	2° 30'	Ø32	110	30		50
DME75-D50-SP12	SPKN 1203 EDR-HPN SPKN 1203 EDSR-HPN SPKN 1203 EDSR-GPN	3	15°	Ø32	110	30		50

	Component			
	Clamp	Clamp Screw	Snap Ring	Wrench
	DCL3C	DCLS3C	DCSR 2	DHLW-3

SPKN 12

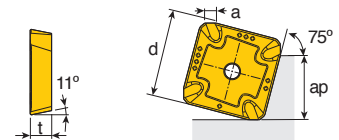

Insert	Designation	Dimension(mm)				Coated					Uncoated	
		d	t	a	ap	DP5320	DP7320	DP9320	DC7800	DC9235	DC210	DC325M
	SPKN 1203 EDR-HPN	12.7	3.18	1.6	8		•					•
	SPKN 1203 EDSR-HPN	12.7	3.18	1.2	8			•		•		
	SPKN 1203 EDSR-GPN	12.7	3.18	1.3	8			•				•

75° ISO Facemill (ISO Insert)

Type 1 (Wedge + Shim Clamp)

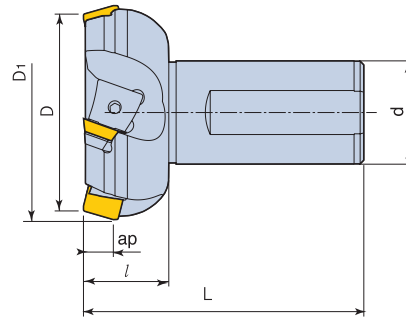

Designation	Insert		Dimension(mm)					
			D	D ₁	d	L	l	ap
DMFN75-D63-SP12	SPKN 1203 EDR-HPN SPKN 1203 EDSR-HPN SPKN 1203 EDSR-GPN	3	63	68.3	32	115	35	8
DMFN75-D80-SP15	SPKN 1504 EDR-HPN SPKN 1504 EDSR-HPN SPKN 1504 EDSR-GPN	4	80	86.9	42	115	35	12

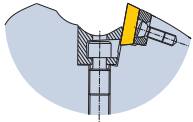

Component	Shim	Wedge	Shim Screw	Wedge Screw	Wrench
	DSSP 12N DSSP 15N	DWPA 8	DS 40B100I-TS	DS 80200W-TS *DS 80160W-TS	DTTW-4

* DS 80160W-TS: For Ø80 cutter

Type 2 (Wedge)

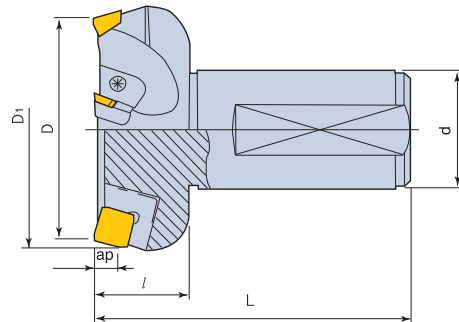
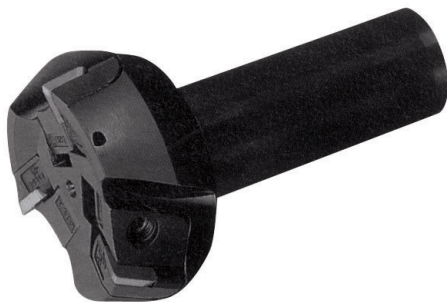

Designation	Insert		Dimension(mm)					
			D	D ₁	d	L	l	ap
DMF75-D63-SP12	SPKN 1203 EDR-HPN SPKN 1203 EDSR-HPN SPKN 1203 EDSR-GPN	3	63	68.3	32	115	35	10
DMF75-D80-SP15	SPKN 1504 EDR-HPN SPKN 1504 EDSR-HPN SPKN 1504 EDSR-GPN	4	80	86.9	42	115	35	14

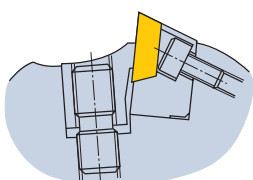

Designation	Component				
	Anvil	Wedge	Anvil Screw	Wedge Screw	Wrench
DMF75-D63-SP12					
	DASP 4NR	DWSP 45R	DS 40E113I/HG-TS	DWS 8/DWS 8M	DTTW-4
DMF75-D80-SP15					
	DASP 45R	DWSP 45R	DS M4X0.7X8-SH	DWS 8/DWS 8M	DTTW-4

SPKN 12/15

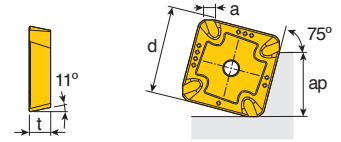

Insert	Designation	Dimension(mm)				Coated					Uncoated	
		d	t	a	ap	DP5320	DP7320	DP9320	DC7800	DC9235	DC210	DC325M
	SPKN 1203 EDR-HPN	12.7	3.18	1.6	8		•					•
	SPKN 1504 EDR-HPN	15.875	4.76	1.6	12	•	•			•		•
	SPKN 1203 EDSR-HPN	12.7	3.18	1.2	8			•		•		
	SPKN 1504 EDSR-HPN	15.875	4.76	1.4	12			•				
	SPKN 1203 EDSR-GPN	12.7	3.18	1.3	8			•				•
	SPKN 1504 EDSR-GPN	15.875	4.76	1.5	12		•	•				•

90° DM Endmill (ISO Insert)

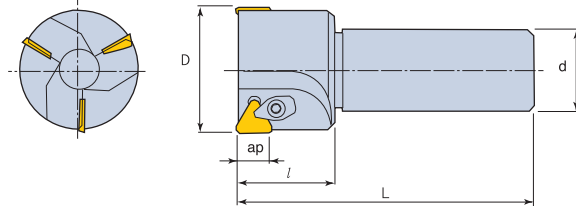

Designation	Insert		Dimension(mm)				
			D	d	L	l	ap
DME90-D25-TP16	TPKN 1603 PPSR-GPN	1	25	25	120	40	14
DME90-D30-TP16		2	30	32	120	40	14
DME90-D32-TP16		2	32	32	120	40	14
DME90-D35-TP16		2	35	32	120	40	14
DME90-D40-TP16		3	40	32	120	40	14
DME90-D50-TP16		3	50	32	120	40	14
DME90-D60-TP16	3	60	32	120	40	14	
DME90-D40-TP22	TPKN 2204 PDR-HPN	2	40	32	120	40	19
DME90-D50-TP22	TPKN 2204 PDSR-HPN	2	50	32	120	40	19
DME90-D60-TP22	TPKN 2204 PDSR-GPN	3	60	32	120	40	19

	Designation	Component			
		Clamp	Clamp Screw	Snap Ring	Wrench
	DME90...TP16				
	DME90...TP22				

TPKN 16/22

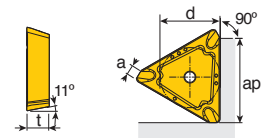

Insert	Designation	Dimension(mm)				Coated					Uncoated	
		d	t	a	ap	DP5320	DP7320	DP9320	DC7800	DC9235	DC210	DC325M
	TPKN 1603 PPSR-GPN	9.525	3.18	1.5	13		•	•		•		
	TPKN 2204 PDR-HPN	12.7	4.76	1.7	16		•			•		•
	TPKN 2204 PDSR-HPN	12.7	4.76	1.41	16			•		•		
	TPKN 2204 PDSR-GPN	12.7	4.76	1.5	16			•				

90° ISO Facemill (ISO Insert)

Type 1 (Wedge + Shim Clamp)

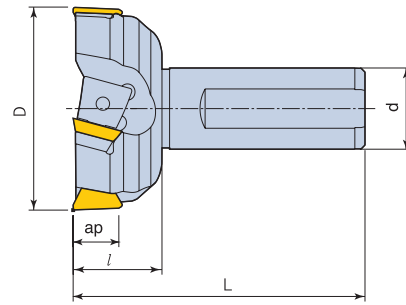

Designation	Insert		Dimension(mm)				
			D	d	L	l	ap
DMFN90-D80-TE22	TEKN 2204 PESR-GPN	4	80	32	115	35	18

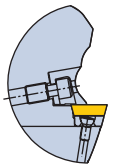

Component	Shim	Wedge	Shim Screw	Wedge Screw	Wrench	Shim Screw Wrench
	DSTE 22N	DWPA 8	DS 40B100I-TS	DS 80160W-TS	DTTW-4	DTTW-15 ⁽¹⁾

• DTTW-15⁽¹⁾ is not included in the package

Type 2 (Wedge)

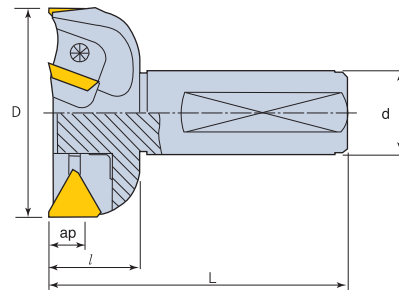
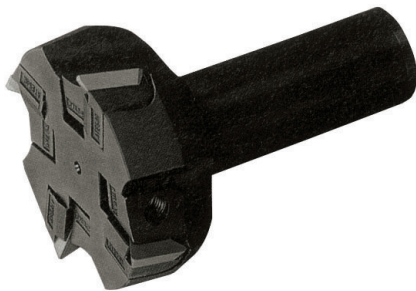

Designation	Insert		Dimension(mm)				
			D	d	L	l	ap
DMF90-D50-TE22	TEKN 2204 PESR-GPN	3	50	32	115	35	19
DMF90-D63-TE22		3	63	32	115	35	19
DMF90-D80-TE22		4	80	32	115	35	19

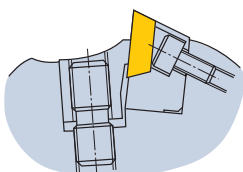

Designation	Component				
	Anvil	Wedge	Anvil Screw	Wedge Screw	Wrench
DMF90-D50-TE22 DMF90-D63-TE22					
	DATEM450R	DWTEMR	SH M3 X 0.5 X 6	DWS8S	DTTW-4
DMF90-D80-TE22					
	DATE54R	DWTE54R	SH M4 X 0.7 X 8	DWS8M	DTTW-4

TEKN 22

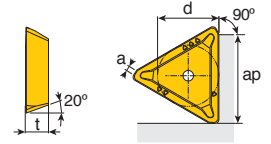

Insert	Designation	Dimension(mm)						Coated					Uncoated	
		d	t	a	ap			DP5320	DP7320	DP9320	DC7800	DC9235	DC210	DC325M
	TEKN 2204 PESR-GPN	12.7	4.76	1.2	17.5				•	•		•		

Recommended Condition of GNMU 11

ISO	Material	Hardness (HB)	Ap (mm)	Speed (m/min)	Recommended Grade	Fz (mm/tooth)
P	Carbon Steel	175 - 225	1.0 - 7.0	180 - 260	DP 5320	0.05 - 0.25
	Alloy Steel	275 - 325	1.0 - 7.0	150 - 230	DP 5320	0.05 - 0.25
	Tool Steel	200 - 250	1.0 - 7.0	90 - 140	DP 5320	0.05 - 0.25
M	Stainless Steel 300 Series		1.0 - 7.0	150 - 240	DP 5320	0.05 - 0.25
	Stainless Steel 400 Series		1.0 - 7.0	150 - 260	DP 5320	0.05 - 0.25

Recommended Condition of GNMU 16

ISO	Material	Hardness (HB)	Ap (mm)	Speed (m/min)	Recommended Grade	Fz (mm/tooth)
P	Carbon Steel	175 - 225	1.0 - 10.0	180 - 260	DP 5320	0.05 - 0.25
	Alloy Steel	275 - 325	1.0 - 10.0	150 - 230	DP 5320	0.05 - 0.25
	Tool Steel	200 - 250	1.0 - 10.0	90 - 140	DP 5320	0.05 - 0.25
M	Stainless Steel 300 Series		1.0 - 10.0	150 - 240	DP 5320	0.05 - 0.25
	Stainless Steel 400 Series		1.0 - 10.0	150 - 260	DP 5320	0.05 - 0.25

Recommended Condition of SNMU 12

ISO	Material	Hardness (HB)	Ap (mm)	Speed (m/min)	Recommended Grade	Fz (mm/tooth)
P	Carbon Steel	175 - 225	1.0 - 6.0	180 - 270	DP 5320	0.10 - 0.25
	Alloy Steel	275 - 325	1.0 - 6.0	135 - 200	DP 5320	0.10 - 0.25
	Tool Steel	200 - 250	1.0 - 6.0	90 - 125	DP 5320	0.10 - 0.25
M	Stainless Steel 300 Series		1.0 - 6.0	150 - 210	DP 5320	0.10 - 0.35
	Stainless Steel 400 Series		1.0 - 6.0	200 - 250	DP 5320	0.10 - 0.35
K	Grey Cast Iron	190 - 220	1.0 - 6.0	180 - 240	DP 5320	0.10 - 0.35
	Ductile Cast Iron	140 - 200	1.0 - 6.0	180 - 240	DP 5320	0.10 - 0.35

Recommended Condition of SEKN 12/15 for 45° Facemill

ISO	Material	Hardness (HB)	Ap (mm)	Speed (m/min)	Recommended Grade***	Fz (mm/tooth) SEKN12/15
P	Low Carbon Steel	85 - 175	1.0	360	DP9320, DC325M	0.15 - 0.30
			2.5	300		0.15 - 0.25
			6.5	270		0.15 - 0.25
	High Carbon Steel	175 - 225	1.0	260	DP9320, DC325M	0.15 - 0.30
			2.5	180		0.15 - 0.25
			6.5	210		0.15 - 0.25
	Alloy Steel	275 - 325	1.0	210	DP9320, DC325M	0.12 - 0.20
			2.5	180		0.10 - 0.15
			6.5	135		0.10 - 0.15
	Tool Steel	200 - 250	1.0	130	DP9320, DC325M	0.12 - 0.20
			2.5	110		0.10 - 0.15
			6.5	100		0.10 - 0.15
K	Grey Cast Iron	190 - 220	1.0	300	DP7320	0.15 - 0.30
			2.5	250		0.15 - 0.25
			6.5	210		0.15 - 0.20
	Ductile Cast Iron	140 - 200	1.0	270	DP7320	0.15 - 0.25
			2.5	240		0.15 - 0.25
			6.5	210		0.15 - 0.20
N	Aluminum Alloy	-	1.0	500+	DC210	0.15 - 0.50
			2.5	500+		0.15 - 0.35
			6.5	500+		0.15 - 0.30

Reduce speed by 20% when channel milling

***In order of preference, uncoated carbide reduce speed 20%

Recommended Condition of SPKN 12/15, TPKN 16/22, SEKN 12/15, TEKN 22 for 75°, 90° Facemill

ISO	Material	Hardness (HB)	Ap (mm)	Speed (m/min)	Recommended Grade***	Fz (mm/tooth) SPKN(R)/TPKN(R)/SEKN/TEKN
P	Low Carbon Steel	85 - 175	1.0	305	DP9320, DC325M	0.10 - 0.15
			2.5	275		0.10 - 0.15
			7.5	240		0.10 - 0.15
	High Carbon Steel	175 - 225	1.0	245	DP9320, DC325M	0.10 - 0.15
			2.5	210		0.10 - 0.15
			7.5	180		0.10 - 0.15
	Alloy Steel	275 - 325	1.0	210	DP9320, DC325M	0.10 - 0.15
			2.5	180		0.10 - 0.15
			7.5	135		0.10 - 0.12
	Tool Steel	200 - 250	1.0	125	DP9320, DC325M	0.05 - 0.15
			2.5	110		0.10 - 0.15
			7.5	90		0.10 - 0.12
M	Stainless Steel 300 Series	-	1.0	210	DP9320, DC325M	0.10 - 0.15
			2.5	180		0.10 - 0.15
			7.5	150		0.10 - 0.12
	Stainless Steel 400 Series	-	1.0	275	DP9320, DC325M	0.10 - 0.15
			2.5	230		0.10 - 0.15
			7.5	210		0.10 - 0.12
S	Heat-Resistance Alloy	-	1.0	45	DP9320	0.10 - 0.12
			2.5	30		0.10 - 0.12
			7.5	25		0.10 - 0.12
	Titanium Alloy	-	1.0	75	DP9320	0.10 - 0.12
			2.5	50		0.10 - 0.12
			7.5	35		0.10 - 0.12
K	Grey Cast Iron	190 - 220	1.0	260	DP7320	0.10 - 0.15
			2.5	230		0.10 - 0.15
			7.5	200		0.10 - 0.15
	Ductile Cast Iron	140 - 200	1.0	230	DP7320	0.10 - 0.15
			2.5	200		0.10 - 0.15
			7.5	170		0.10 - 0.15
N	Aluminum Alloy	-	1.0	500+	DC210	0.15 - 0.50
			2.5	450+		0.15 - 0.35
			7.5	360+		0.15 - 0.35

Reduce speed by 20% when channel milling

***In order of preference, uncoated carbide reduce speed 20%

Recommended condition of OFCN, OFCR for 43° Facemill

ISO	Material	Hardness (HB)	Ap (mm)	Speed (m/min)	Recommended Grade***	Fz (mm/tooth)** OFCN, OFCR
P	Low Carbon Steel	85 - 175	1.0	360	DP9320	0.15 - 0.35
			2.5	300		0.15 - 0.30
			6.5	270		0.15 - 0.30
	High Carbon Steel	175 - 225	1.0	260	DP9320	0.10 - 0.30
			2.5	180		0.10 - 0.25
			6.5	210		0.10 - 0.25
	Alloy Steel	275 - 325	1.0	210	DP9320	0.10 - 0.18
			2.5	180		0.10 - 0.16
			6.5	135		0.10 - 0.16
	Tool Steel	200 - 250	1.0	130	DP9320	0.10 - 0.18
			2.5	110		0.10 - 0.16
			6.5	100		0.10 - 0.16
K	Grey Cast Iron	190 - 220	1.0	300	DP7320	0.15 - 0.35
			2.5	250		0.15 - 0.35
			6.5	210		0.15 - 0.30
	Ductile Cast Iron	140 - 200	1.0	270	DP7320	0.10 - 0.25
			2.5	240		0.10 - 0.25
			6.5	210		0.10 - 0.25

Reduce speed by 20% when channel milling

***In order of preference, uncoated carbide reduce speed 20%

**Feed (mm/tooth) adjusted to compensate for radial chip thinning

Recommended Condition APKT 16 for 90° Facemill

ISO	Material	Hardness (HB)	Ap (mm)	Speed (m/min)	Recommended Grade	Fz (mm/tooth) APKT 16
P	Low Carbon Steel	85 - 175	1.0	350	DP9320	0.10 - 0.25
			3.5	320		0.10 - 0.22
			7.0	280		0.10 - 0.20
	High Carbon Steel	175 - 225	1.0	260	DP9320	0.10 - 0.22
			3.5	230		0.10 - 0.20
			7.0	180		0.10 - 0.20
	Alloy Steel	275 - 325	1.0	230	DP9320	0.10 - 0.20
			3.5	180		0.10 - 0.15
			7.0	150		0.10 - 0.12
	Tool Steel	200 - 250	1.0	140	DP9320	0.10 - 0.18
			3.5	120		0.10 - 0.15
			7.0	90		0.10 - 0.12
K	Grey Cast Iron	190 - 220	1.0	300	DP7320	0.10 - 0.25
			3.5	250		0.10 - 0.20
			7.0	200		0.10 - 0.15
	Ductile Cast Iron	140 - 200	1.0	280	DP7320	0.10 - 0.22
			3.5	220		0.10 - 0.18
			7.0	150		0.10 - 0.15

Reduce speed by 25% when endmill diameter is less than 18mm and DOC is bigger than 3.5mm

Reduce 20% speed by 20% for Facemills when slotting

Technical Information

Grade Comparison Table

	Duracarb	Korloy	Sandvik	Walter	Seco	Kennametal	Mitsubishi	Sumitomo	Tungaloy	Kyocera	TaeguTec	ISCAR
Turning	DC210	H01	H10 H10A		HX		HT10	H1 EH10	G1F H10T TH10		K10	IC20
	DC610	CN1000 CN2000	CT5015 CT5005	WCE10	CM CM15	KT125 KT150	NX2525 NX3035	T110A T1200A	NS730 NS720	TN60 TN6020	CT3000	IC20N
	DC820	NC305K NC6110	GC3205 GC3210	WAK10 WAK20	TK1000 TK2000	KCK05 KCK15	UC5105 UC5115	AC410K AC700G	T5105 T5115 T5125	CA4505 CA4515	TT1300 TT7310	IC5005 IC5010
	DC9015	NC3010 NC3015	GC4205 GC4215	WPP01 WPP10 WAP10	TP1000 TP1500	KCP05 KCP10	UE6105 UE6110	AC1000 AC700G	T9005 T9015 T9115	CA5505 CA5515 CR7015	TT8115	IC8150 IC9150
	DC9025	NC3120 NC3020	GC4225 GC4025	WPP20 WAP20	TP2000 TP2500	KCP25 KC9125	UE6020	AC820P AC2000	T9125 T9025	CA5525 CR7025	TT8125 TT5100	IC8250 IC9250
	DC8035											
D-Cut	DC210	H01	H10 H10A		HX		HT10	H1 EH10	G1F H10T TH10		K10	IC20
	DC9235	PC3545 PC5300	GC2040 S40T	WXM35 WSM35 WSP45	F40M MM4500 MS2500	KC725M	F7030 VP30RT MP9030	ACP300 EH202 EH5202	AH130 AH140 SH730	PR1225 PR905	TT8020	IC830 IC330 IC928
Milling	DC210	H01	H10 H10A		HX		HT10	H1 EH10	G1F H10T TH10		K10	IC20
	DC325M		S30 SM30		S35M			A30N A30	TX30 UX30		P30	IC50M
	DC9200	PC6510 PC215K	GC1020		MK2000	KC915M	F5010	ACZ310 ACK200 ACK300	AH120		TT6030	IC810 IC910
	DC9300	PC3500 PC3535 PC3525 PC130	GC4020	WAM20	T250M				AH330	PR630 PR660 PR730	TT7030	IC950
	DC7320	PC6510 PC215K PC5300	GC3020 GC1020	WKP25 WKP35	MK2000 MK3000	KCK15 KC520M	MP8010 VP15TF F5010	ACK200 ACK300 ACK310	T1015 T1115 AH120 GH110	PR905 PR510 PR610	TT6080	IC810 IC910
	DC9235	PC3545 PC5300	GC2040 S40T	WXM35 WSM35 WSP45	F40M MM4500 MS2500	KC725M	F7030 VP30RT MP9030	ACP300 EH202 EH5202	AH130 AH140 SH730	PR1225 PR905	TT8020	IC830 IC330 IC928
	DP8330	PC3545 PC5300	GC2040 S40T	WXM35 WSM35 WSP45	F40M MM4500 MS2500	KC725M	F7030 VP30RT MP9030	ACP300 EH202 EH5202	AH130 AH140 SH730	PR1225 PR905	TT8080	IC830 IC330 IC928
	DP9320	PC3500 PC3535 PC3525	GC4220 GC4230	WAP25 WAM10	MP1500 MP2500				T3130 AH330	PR630 PR660 PR730	TT7080	IC950
	DC9800	PC5300 NC5330 PC9530	GC1030 GC4240	WAMB0	F30M MP3000	KC522M KC635M	VP15TF VP20RT	ACP200	AH725 AH730 GH330 AH120	PR830	TT9030	IC808 IC908
	DP5320	PC5300 NC5330 PC9530	GC1030 GC4240	WAMB0	F30M MP3000	KC522M KC635M	VP15TF VP20RT	ACP200	AH725 AH730 GH330 AH120	PR830	TT9080	IC808 IC908
	DC7800	PC3545 PC5300	GC2040 S40T	WXM35 WSM35 WSP45	F40M MM4500 MS2500	KC725M	F7030 VP30RT MP9030	ACP300 EH202 EH5202	AH130 AH140 SH730	PR1225 PR905	TT7800	IC830 IC330 IC928
	DC150	PC3500	GC1025 GC4125								TT7220	IC350
Drilling	DC9800	PC9530	GC1030 GC2030	WAMB0	F30M	KC522M KC635M	VP15TF	ACP200	GH330	PR830 PR925 PR1025	TT9030	IC808 IC908
	DC154	PC3500	GC1025 GC4125								TT7220	IC350

Technical information

Chipbreaker

Description			Duracarb	TaeguTec	Mitsubishi	Sumitomo	Kyocera	Tungaloy	Korloy	Sandvik	Kennametal	Seco	Walter	ISCAR	
Negative	Steel	Double sided	41	FG	SY	SU	HQ	TSF	VF	QF	FP	MF2	NF3	NF	
				FC	SH	LU		TF	GF	PF	FN				
			43	FC	SA	GE	CQ	TSF	VC	PF	FN	MF3	NS6	TF	
				PC	SH		PS	TM							
			46	MT	MV	GU	HS	TM	VM	PM	MN	M3	NM6	GN	
	52	MC	MH	UX	GS	AS	HC	SM	MP	MR3	NM4				
	53	-MG	MG-	UZ	C	MG-	B25		MG		MG				
	Stainless Steel	Double sided	42	EM	MS	EX	MU, MS	SS	HS	MM	UP	MF4	NMS	TMN	
			45	ET	MA	GU	HU	SM	GS	MR	RP	MF5	NR4		
	Cast Iron	Double sided	52	MC	MH	UX	GS	AS	HC	SM	MP	MR3	NM6		
53			-MG	MG-	UZ	C	MG-	B25		MG		MG			
Positive	Steel		51	FG	SQ	LU	GP	PF	HPF	PF	FP, LF	F1	PS4	SM	
			41	FM	SV	SU	HQ	PS	HMP	PM	MP		PF2	17	
			52	MT	MT	MU	MT	PM	C25	PR	MF	F2	PM5	19	
	Aluminum	AU	FL	AZ	AG	AH	AL	AR	AL	HP	AL	PM2	AF,AS		

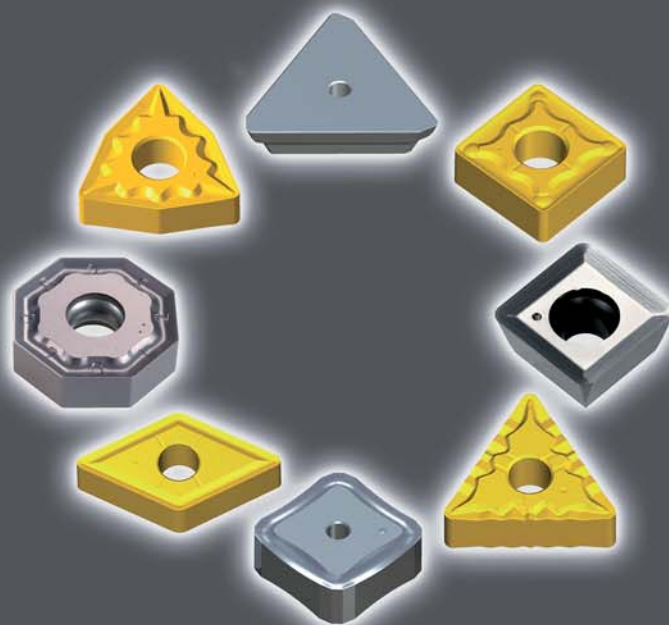

Duracarb

Products Catalog

info@duracarb.com